

Superior Efficacy & Lumen output

Z Power LED – Z5-M4 Blue

S1CH-3535450003-00000000-00004 **Royal Blue(455)**

S1CH-3535470003-00000000-00004 **Blue(470)**

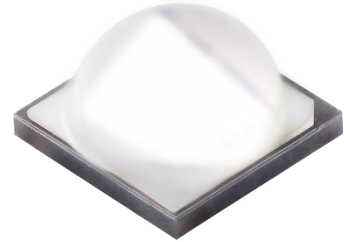

Product Brief

Description

- The Z-Power series is designed for high flux output applications with high current operation capability.
- It incorporates state of the art SMD design and low thermal resistant material.
- The Z Power LED is ideal source for high flux blue light source such as Horticulture, Landscape, and various outdoor applications.

Features and Benefits

- High Flux Output and High Efficacy
- Designed for high current operation
- Low Thermal Resistance
- SMT solder able
- Lead Free Product
- RoHS compliant

Key Applications

- Horticulture
- Architectural
- Projector light source
- Commercial



Table 1. Product Selection (Order Code Table)

Part Number	Color	Typical Wavelength	Order Code
SZ5-M4-B0-00	Royal Blue	455 nm	S1CH-3535450003-00000000-00004
SZ5-M4-B1-00	Blue	470 nm	S1CH-3535470003-00000000-00004

Table of Contents

Index	
• Product Brief	1
• Table of Contents	3
• Performance Characteristics	4
• Characteristics Graph	7
• Mechanical Dimensions	14
• Recommended Solder Pad	15
• Reflow Soldering Characteristics	16
• Emitter Tape & Reel Packaging	17
• Packaging Information	18
• Product Nomenclature	19
• Handling of Silicone Resin for LEDs	20
• Precaution For Use	21
• Company Information	24

Performance Characteristics

Table 2. Characteristics at 700mA (Ta=25°C, RH30%)

Parameter	Symbol	Value			Unit	
		Min.	Typ.	Max.		
Radiant Power (@Royal Blue) [1]	Φ_E	-	1370	-	mW	
Luminous Flux (@Blue) [1]	Φ_V	-	75	-	lm	
Dominant Wavelength	λ_D	Royal Blue	445	-	460	nm
		Blue	465	-	475	nm
PPF [2] (@Royal Blue)	Φ_p	-	5.23	-	$\mu\text{mol/s}$	
PPE [3] (@Royal Blue)	K_p	-	2.50	-	$\mu\text{mol/J}$	
Forward Voltage [4]	V_F	2.75	3.05	3.25	V	
Viewing angle	θ		125		degree	
Thermal resistance (J to S) [5]	$R\theta_{J-S}$	-	3.0	-	K/W	

Table 3. Absolute Maximum Ratings

Parameter	Symbol	Value			Unit
		Min.	Typ.	Max. [7]	
Forward Current	I_F	-	700	1400	mA
Reverse Voltage	V_R	-	-	5	V
Junction Temperature	T_j	-	-	135	°C
Storage Temperature	T_{stg}	- 10	-	85	°C
ESD Sensitivity(HBM) [6]		Class 3B JEDEC JS-001-2017			

Notes :

- (1) SSC maintains a tolerance of $\pm 7\%$ on power measurements.
- (2) Photosynthetic Photon Flux includes wavelengths between 400 and 700 nm.
- (3) Photosynthetic Photon Efficacy includes wavelengths between 400 and 700 nm.
- (4) Tolerance is $\pm 0.06\text{V}$ on forward voltage measurements
- (5) $R\theta_{J-S}$ is tested at 700mA.
- (6) The zener diode is included to protect the product from ESD
- (7) It is recommended to use it in the condition that the reliability is secured within the Max value.

- Thermal resistance can be increased substantially depending on the heat sink design/operating condition, and the maximum possible driving current will decrease accordingly.

Performance Characteristics

Table 3-1. Bin Code Description - Royal Blue (455), $I_F=700\text{mA}$, $T_a=25^\circ\text{C}$

Bin Code								
Radiant Power (mW) @ $I_F = 700\text{mA}$			Dominant Wavelength (nm) @ $I_F = 700\text{mA}$			Forward Voltage (V) @ $I_F = 700\text{mA}$		
M41			B13			G0		

Radiant Power (mW) ⁽¹⁾ @ $I_F = 700\text{mA}$				Dominant Wavelength (nm) @ $I_F = 700\text{mA}$				Forward Voltage (V) ⁽²⁾ @ $I_F = 700\text{mA}$			
Bin Code	Min.	Max.		Bin Code	Min.	Max.		Bin Code	Min.	Max.	
M32	1,250	1,300		B13	445	450		F2	2.55	2.75	
M41	1,300	1,350		B14	450	455		G0	2.75	2.95	
M42	1,350	1,400		B15	455	460		G1	2.95	3.15	
P11	1,400	1,460									
P12	1,460	1,520									

Table 4. Brightness Groups

Part no	Color	Typical Wavelength [nm]	Flux Rank	R-Flux [mW]		PPF ⁽³⁾ [$\mu\text{mol/s}$]		PPF/W [$\mu\text{mol/J}$]
				min	Max	min	max	typ
SZ5-M4-B0-00	Royal Blue	455	M32	1250	1300	4.75	4.94	2.32
			M41	1300	1350	4.94	5.13	2.41
			M42	1350	1400	5.13	5.32	2.50
			P11	1400	1460	5.32	5.55	2.60
			P12	1460	1520	5.55	5.78	2.71

Notes : (1) Seoul Semiconductor maintains a tolerance of $\pm 7\%$ on flux and power measurements.

(2) Tolerance is $\pm 0.06\text{V}$ on forward voltage measurements

(3) Photosynthetic Photon Flux includes wavelengths between 400 and 700 nm

Performance Characteristics

Table 3-2. Bin Code Description - Blue (470), $I_F=700\text{mA}$, $T_a=25^\circ\text{C}$

Bin Code		
Luminous Flux (lm) @ $I_F = 700\text{mA}$	Dominant Wavelength (nm) @ $I_F = 700\text{mA}$	Forward Voltage (V) @ $I_F = 700\text{mA}$
S1	B21	G0



Luminous Flux (lm) ⁽¹⁾ @ $I_F = 700\text{mA}$			
Bin Code	Min.	Max.	
R6	65	70	
S1	70	78	
S2	78	86	
S3	86	94	
S4	94	102	

Dominant Wavelength (nm) @ $I_F = 700\text{mA}$			
Bin Code	Min.	Max.	
B21	460	465	
B22	465	470	
B23	470	475	

Forward Voltage (V) ⁽²⁾ @ $I_F = 700\text{mA}$			
Bin Code	Min.	Max.	
F2	2.55	2.75	
G0	2.75	2.95	
G1	2.95	3.15	

- Notes :** (1) Seoul Semiconductor maintains a tolerance of $\pm 7\%$ on flux and power measurements.
 (2) Tolerance is $\pm 0.06\text{V}$ on forward voltage measurements

Characteristics Graph

Fig 1. Color Spectrum, $T_a=25^\circ\text{C}$

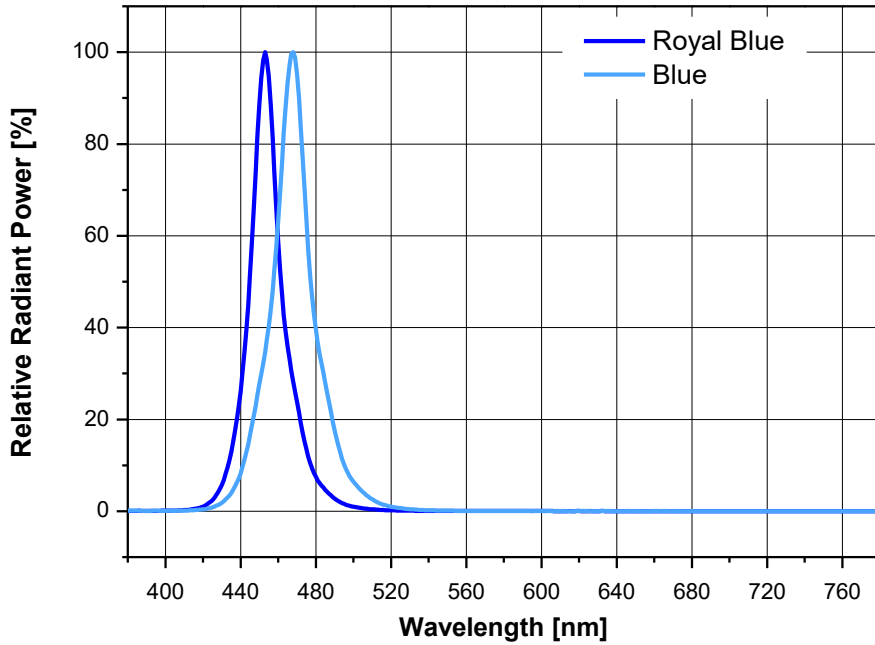
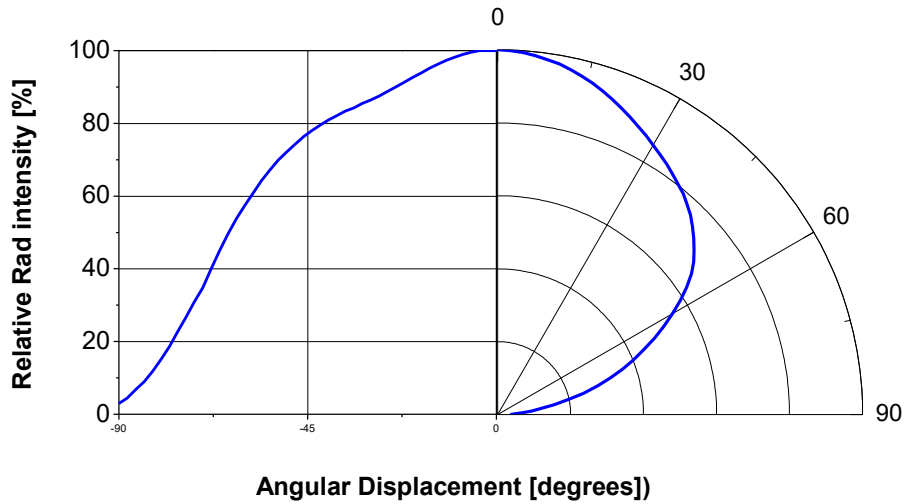

Fig 2. Typical Spatial Distribution, $T_a=25^\circ\text{C}$



Characteristics Graph

Fig 3. Forward Voltage vs. Forward Current, $T_a=25^\circ\text{C}$

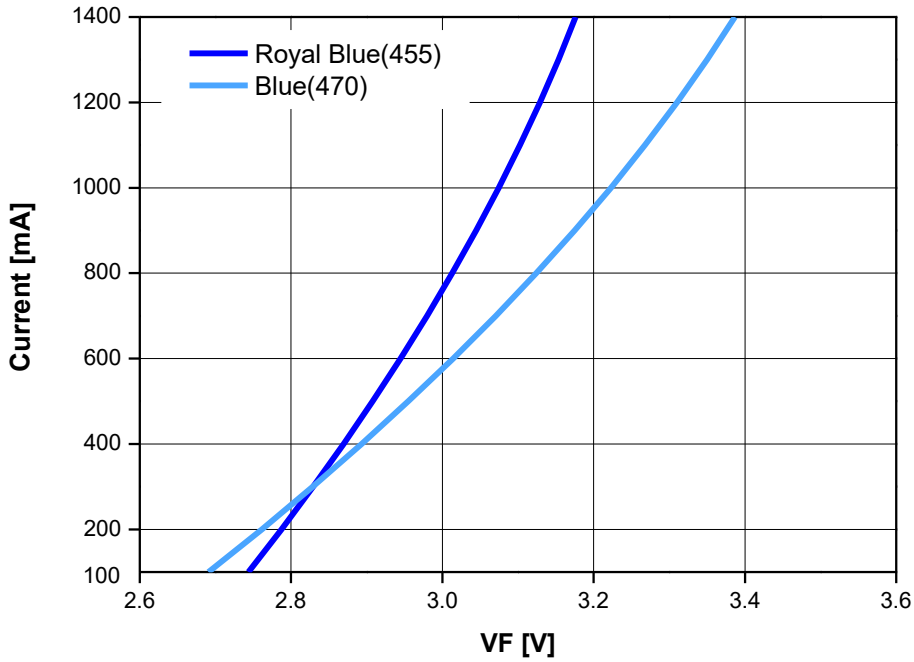
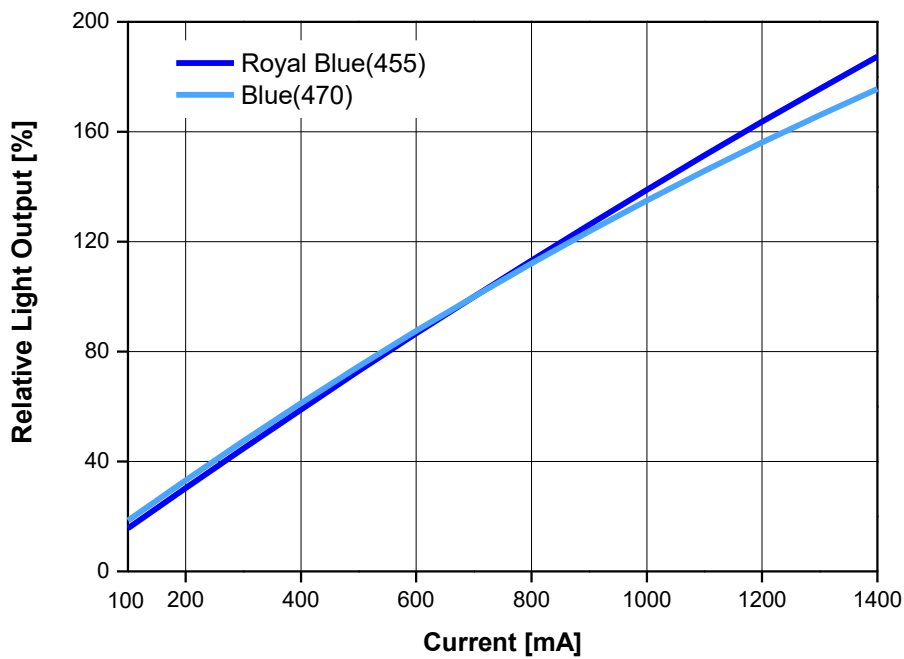

Fig 4. Forward Current vs. Relative Light Output, $T_a=25^\circ\text{C}$



- Using less than 100mA is not recommended

Characteristics Graph

Fig 5. Forward Current vs. Dominant Wavelength, $T_a=25^{\circ}\text{C}$

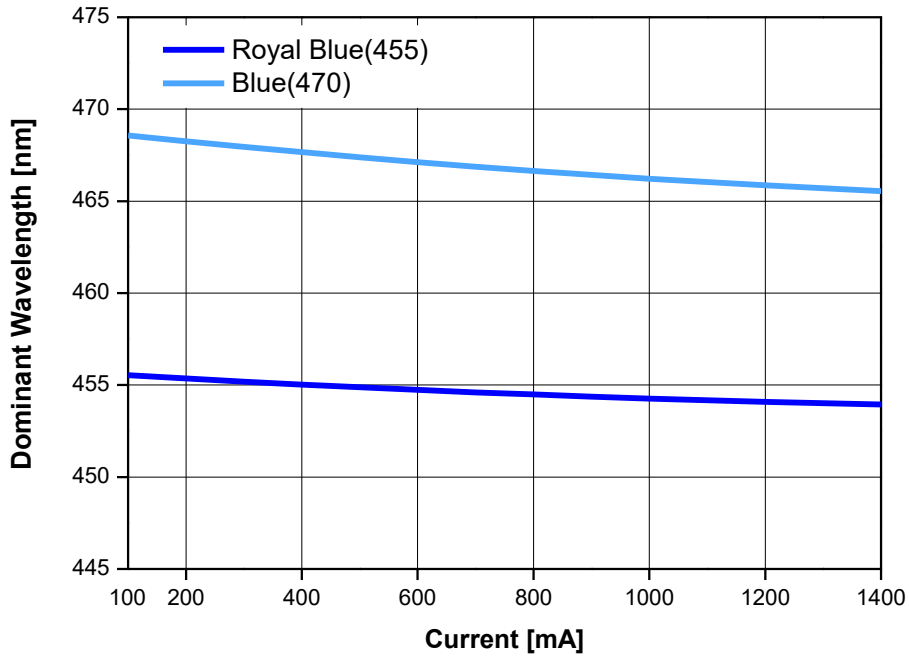

- Using less than 100mA is not recommended

Characteristics Graph

Fig 6. Relative Light Output vs. Junction Temperature, $I_F=700\text{mA}$

SZ5-M4-B0-00(455nm Royal Blue)

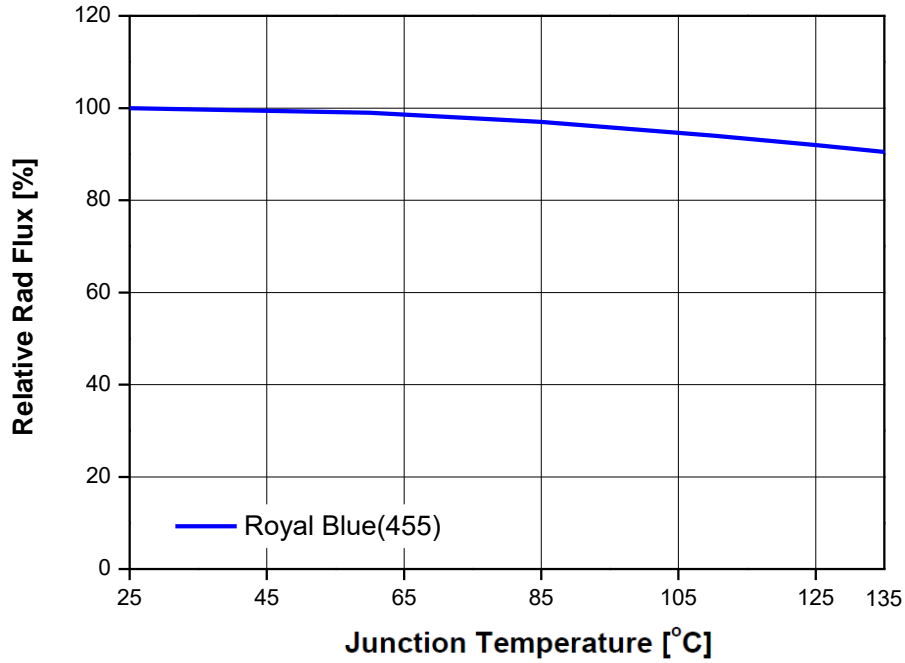

SZ5-M4-B1-00(470nm Blue)

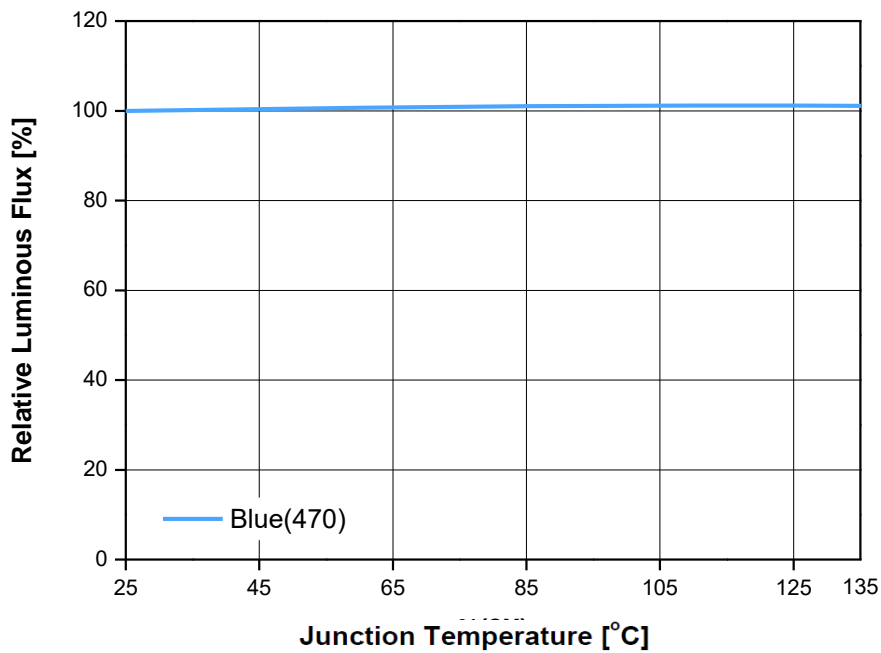

Characteristics Graph

Fig 7. Relative Forward Voltage vs. Junction Temperature, $I_F=700\text{mA}$

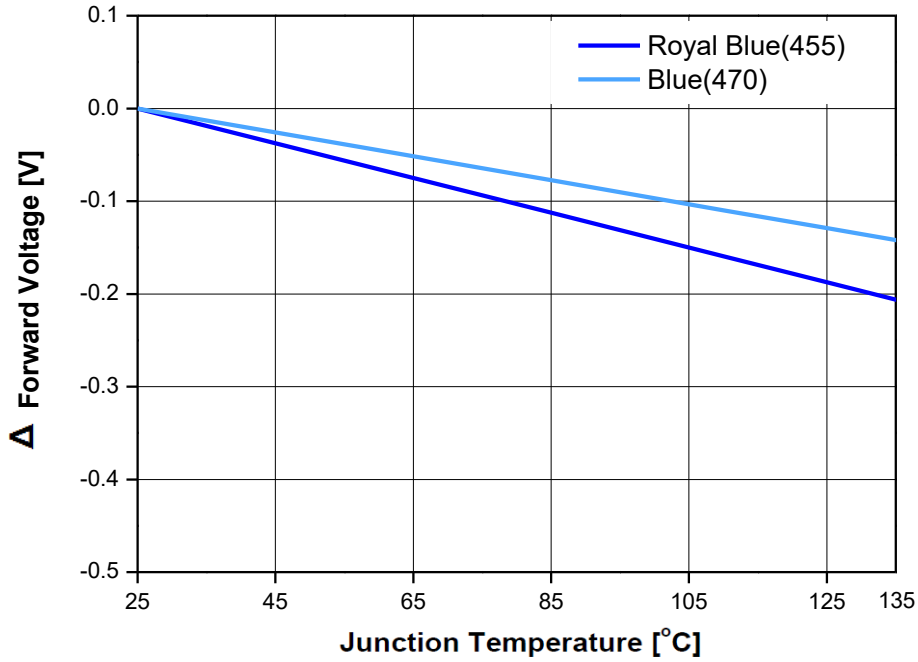
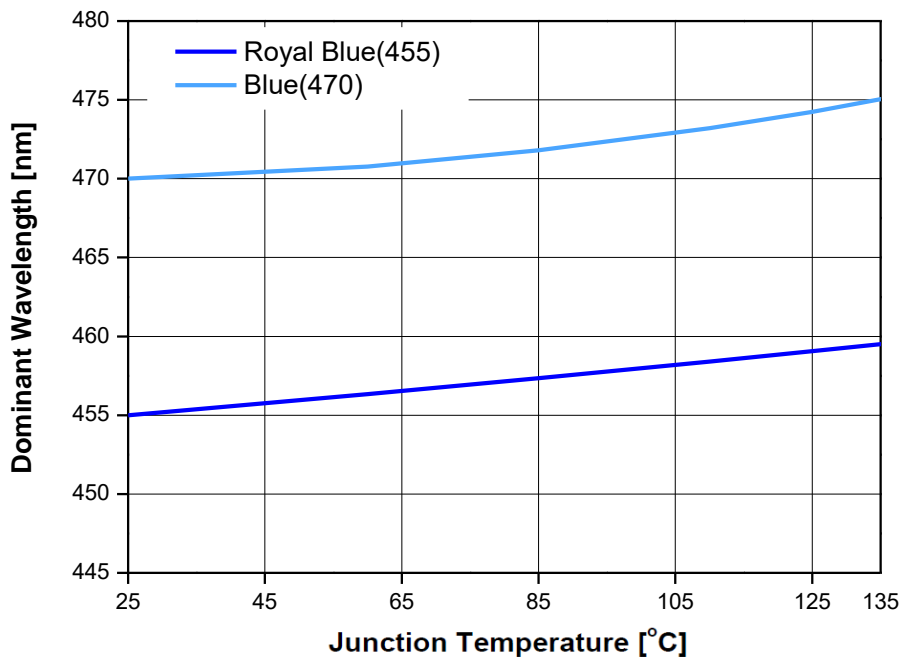
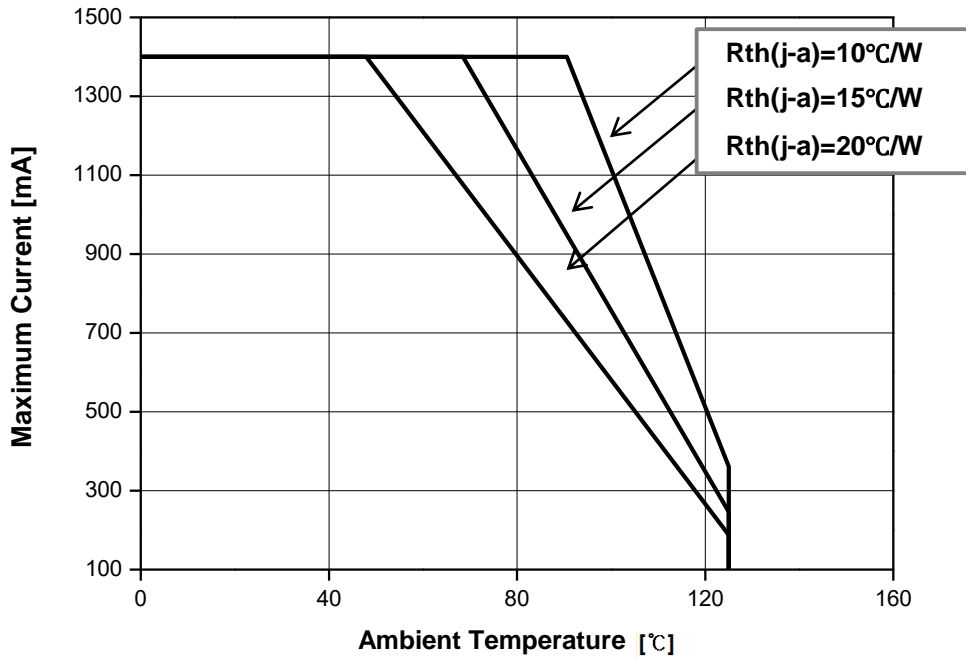

Fig 8. Junction Temperature vs. Dominant Wavelength, $I_F=700\text{mA}$



Characteristics Graph

Fig 9. Maximum Forward Current vs. Ambient Temperature, $T_j(\text{max.})=135^\circ\text{C}$



- Using less than 100mA is not recommended

Characteristics Graph

Fig 10-1. Current vs $\mu\text{mol/s}$ characteristics

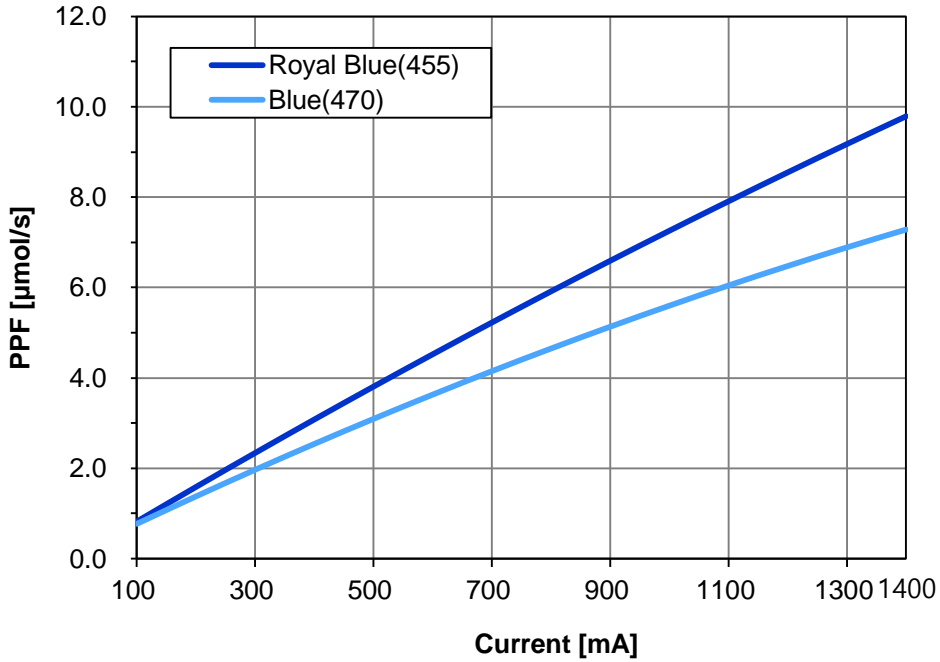
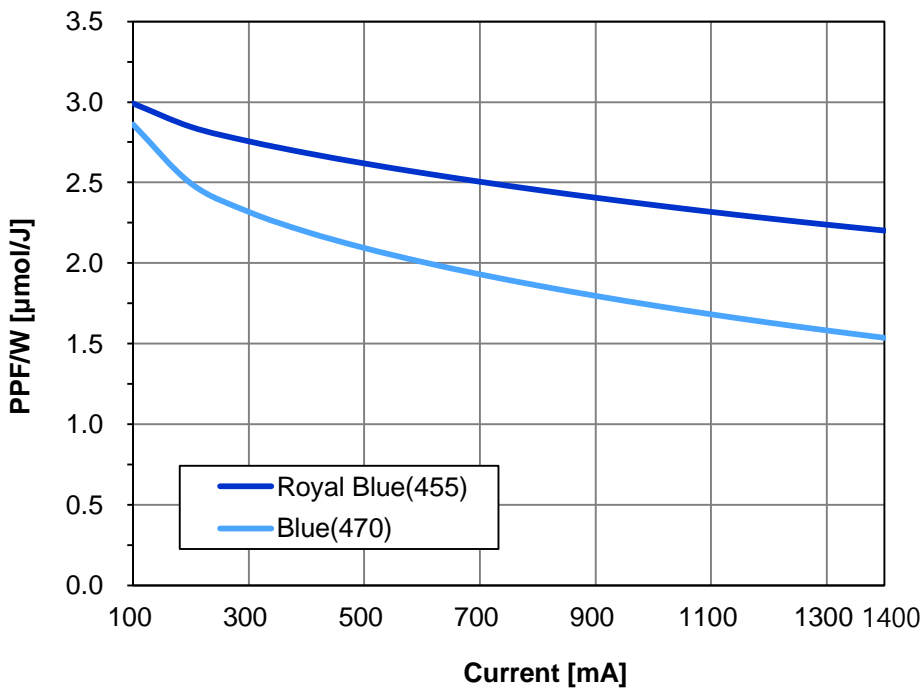
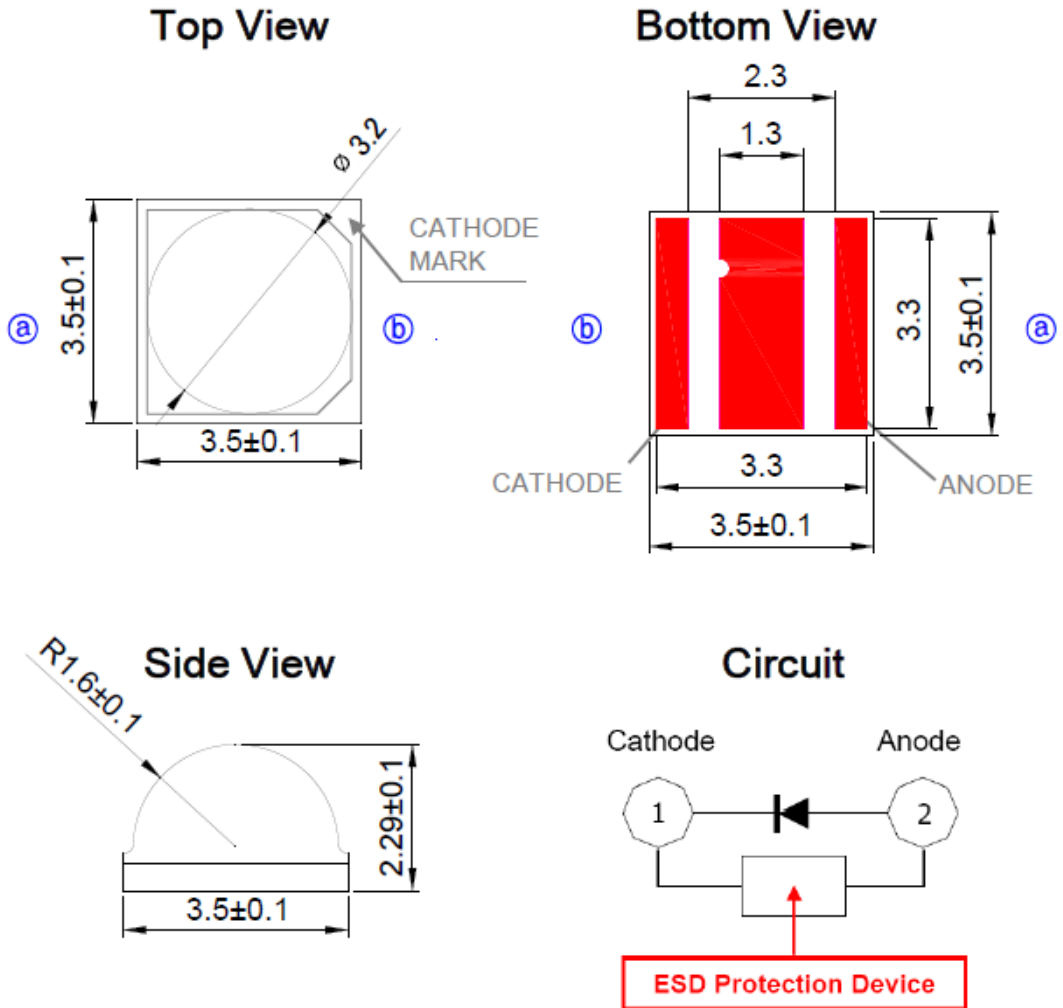

Fig 10-1. Current vs $\mu\text{mol/s}$ characteristics



- Using less than 100mA is not recommended

Mechanical Dimensions



- (1) All dimensions are in millimeters.
- (2) Scale : none
- (3) Undefined tolerance is ± 0.1 mm

Recommended Solder Pad

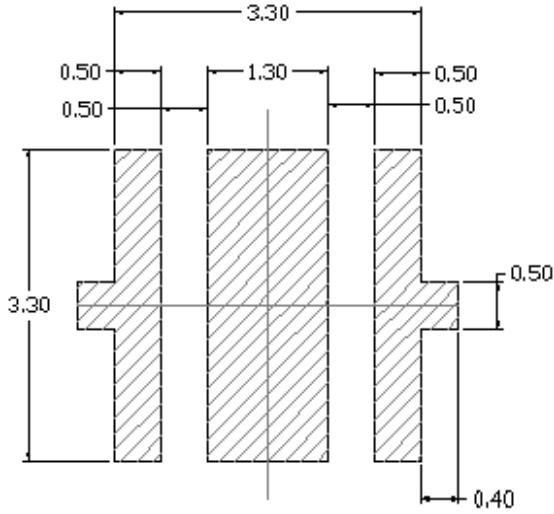

Recommended PCB Solder Pad

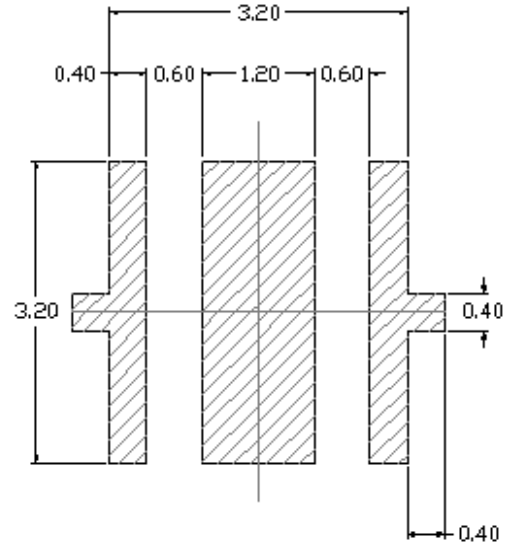

Recommended Stencil Pattern

- (1) All dimensions are in millimeters.
- (2) Scale : none
- (3) This drawing without tolerances are for reference only.
- (4) Undefined tolerance is $\pm 0.1\text{mm}$.

Reflow Soldering Characteristics

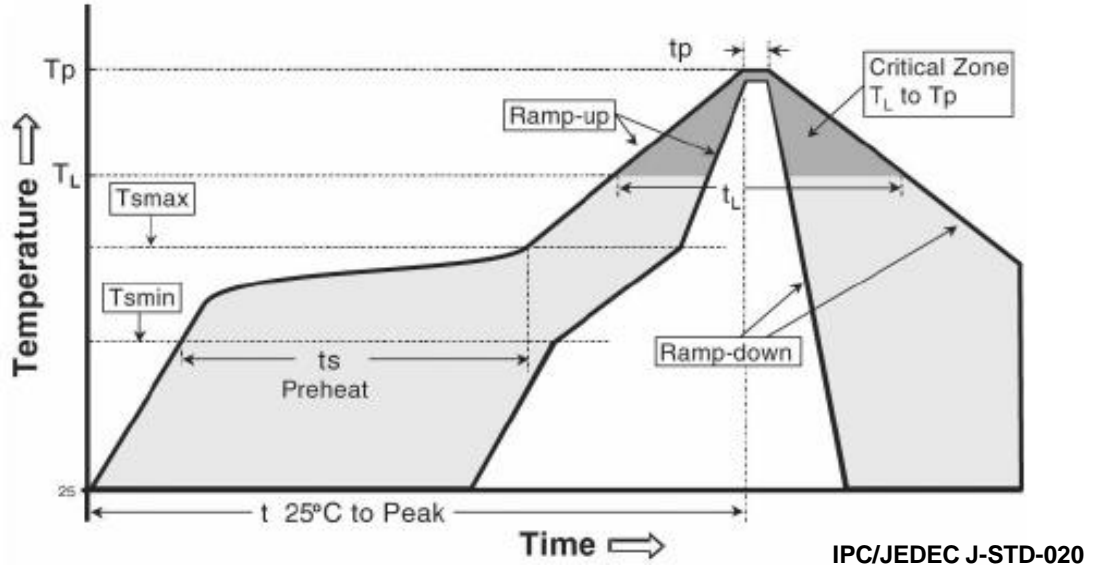

Profile Feature	Sn-Pb Eutectic Assembly	Pb-Free Assembly
Average ramp-up rate (T _{smax} to T _p)	3° C/second max.	3° C/second max.
Preheat - Temperature Min (T _{smin}) - Temperature Max (T _{smax}) - Time (T _{smin} to T _{smax}) (t _s)	100 °C 150 °C 60-120 seconds	150 °C 200 °C 60-180 seconds
Time maintained above: - Temperature (T _L) - Time (t _L)	183 °C 60-150 seconds	217 °C 60-150 seconds
Peak Temperature (T _p)	215°C	260°C
Time within 5°C of actual Peak Temperature (t _p) ²	10-30 seconds	20-40 seconds
Ramp-down Rate	6 °C/second max.	6 °C/second max.
Time 25°C to Peak Temperature	6 minutes max.	8 minutes max.

Caution

- (1) Reflow soldering is recommended not to be done more than two times. In the case of more than 24 hours passed soldering after first, LEDs will be damaged.
- (2) Repairs should not be done after the LEDs have been soldered. When repair is unavoidable, suitable tools must be used.
- (3) Die slug is to be soldered.
- (4) When soldering, do not put stress on the LEDs during heating.
- (5) After soldering, do not warp the circuit board.

Emitter Tape & Reel Packaging

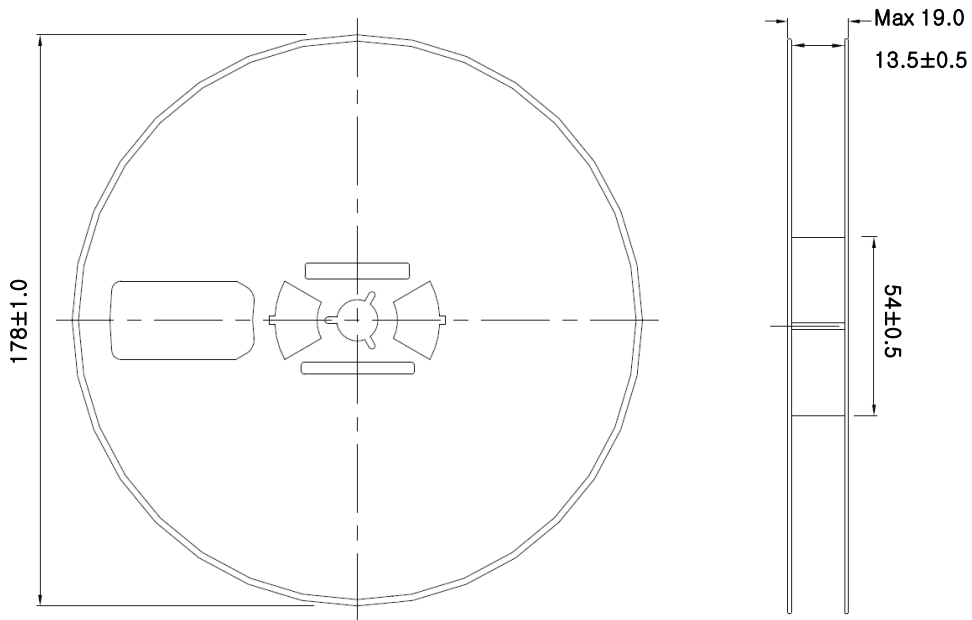
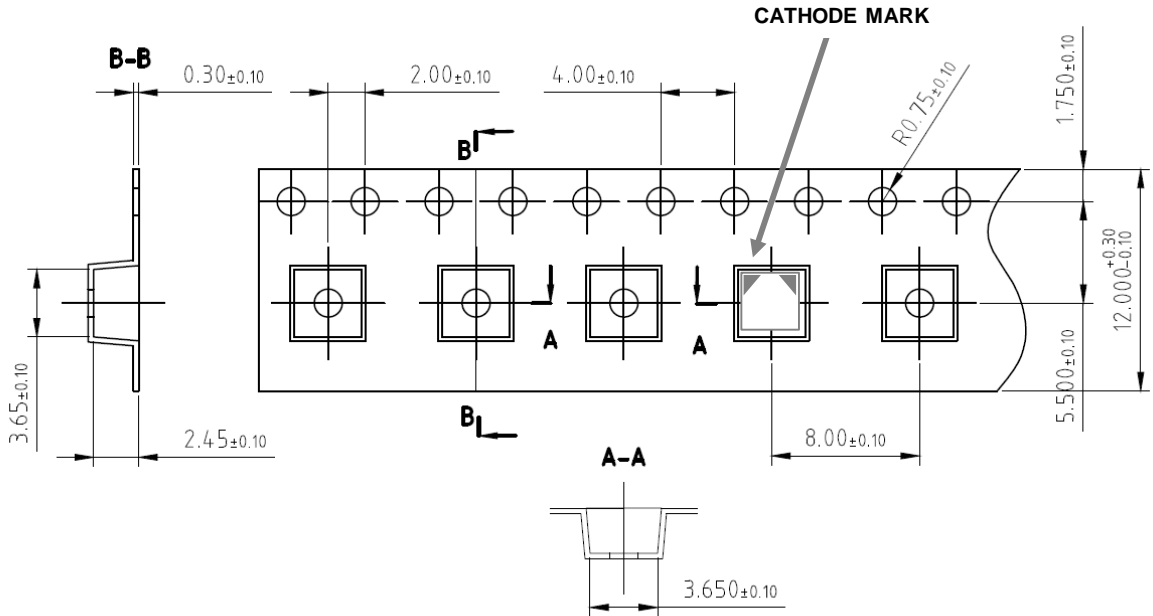

Notes :

UNIT: mm

- Quantity : 900pcs/Reel
- Cumulative Tolerance : Cumulative Tolerance/10 pitches to be $\pm 0.2\text{mm}$
- Adhesion Strength of Cover Tape : Adhesion strength to be 10-60g when the cover tape is turned off from the carrier tape at the angle of 10° to the carrier tape
- Package : P/N, Manufacturing data Code No. and quantity to be indicated on a damp proof Package

Packaging Information

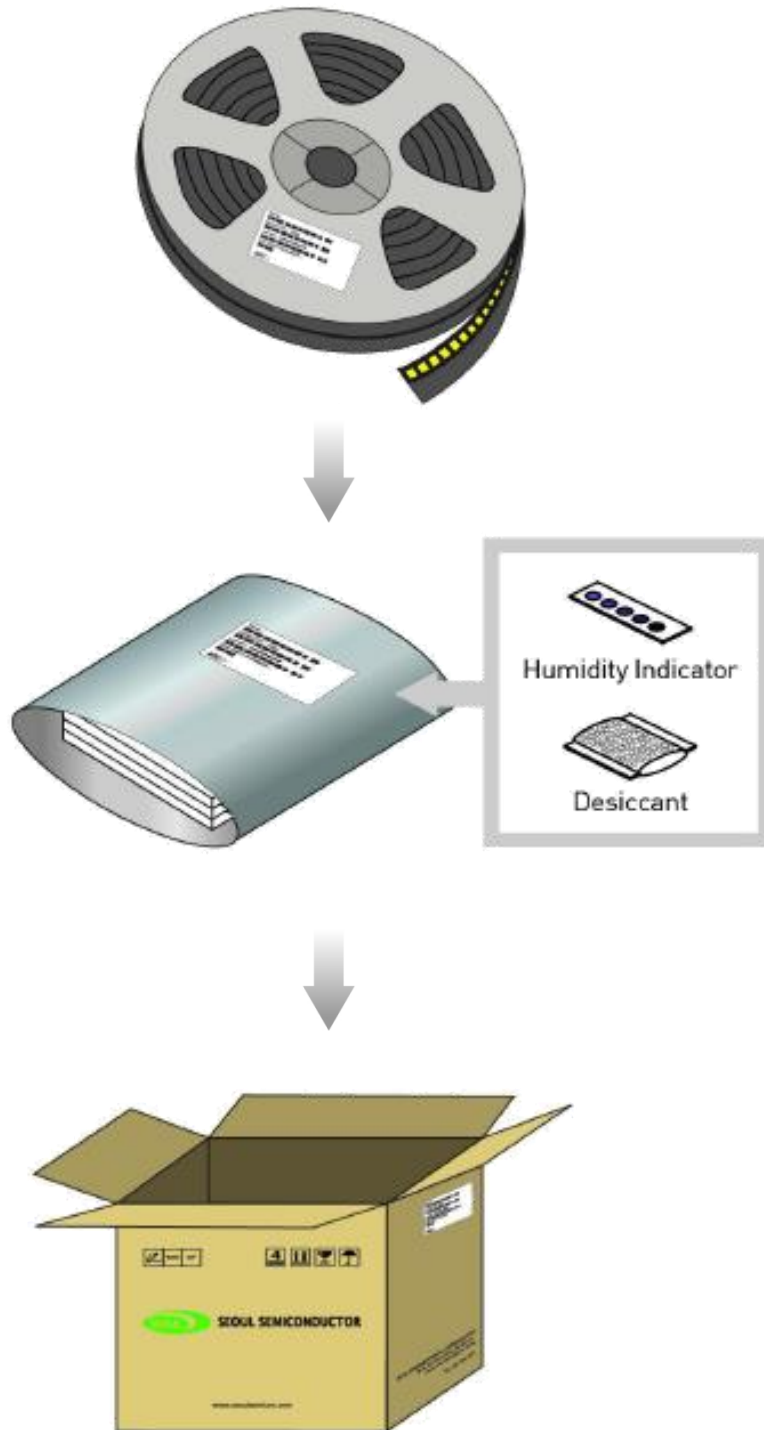

Product Nomenclature

Table 10. Order Code example

S 1 C H - 3 5 3 5 4 5 0 0 0 3 - 0 0 0 0 0 0 0 0 - 0 0 0 0 4
 X₁ X₂ X₃ X₄ X₅ X₆ X₇ X₈ X₉ X₁₀ X₁₁ X₁₂ X₁₃ X₁₄ X₁₅ X₁₆ X₁₇ X₁₈ X₁₉ X₂₀ X₂₁ X₂₂ X₂₃ X₂₄ X₂₅ X₂₆ X₂₇ X₂₈ X₂₉ X₃₀

Code digits	Value	References	Description
X ₁	S	Seoul Semiconductor	
X ₂	1	Discrete LED	
X ₃ X ₄	CH	Color Horticulture	
X ₅	-		
X ₆ X ₇ X ₈ X ₉	3535	PKG size	
X ₁₀ X ₁₁	45	Wavelength	45= 450nm, 47=470nm
X ₁₂ X ₁₃	00	Color	
X ₁₄ X ₁₅	03	Voltage	
X ₁₆	-		
X ₁₇ X ₁₈ X ₁₉	000	Flux Rank	000=Full
X ₂₀ X ₂₁ X ₂₂	000	Vf Rank	000=Full
X ₂₃ X ₂₄	00	Color Step	00=Full
X ₂₅	-		
X ₂₆ X ₂₇	00	Type	
X ₂₈ X ₂₉ X ₃₀	004	Z5M4	PKG type internal code

Handling of Silicone Resin for LEDs

- (1) During processing, mechanical stress on the surface should be minimized as much as possible. Sharp objects of all types should not be used to pierce the sealing compound.



- (2) In general, LED should only be handled from the side. By the way, this also applies to LED without a silicone sealant, since the surface can also become scratched.
- (3) When populating boards in SMT production, there are basically no restrictions regarding the form of the pick and place nozzle, except that mechanical pressure on the surface of the resin must be prevented. This is assured by choosing a pick and place nozzle which is larger than the LED's reflector area.
- (4) Silicone differs from materials conventionally used for the manufacturing of LEDs. These conditions must be considered during the handling of such devices. Compared to standard encapsulants, silicone is generally softer, and the surface is more likely to attract dust. As mentioned previously, the increased sensitivity to dust requires special care during processing. In cases where a minimal level of dirt and dust particles cannot be guaranteed, a suitable cleaning solution must be applied to the surface after the soldering of components.
- (5) Seoul Semiconductor suggests using isopropyl alcohol for cleaning. In case other solvents are used, it must be assured that these solvents do not dissolve the package or resin. Ultrasonic cleaning is not recommended. Ultrasonic cleaning may cause damage to the LED.
- (6) Please do not mold this product into another resin (epoxy, urethane, etc) and do not handle this product with acid or sulfur material in sealed space.
- (7) Avoid leaving fingerprints on silicone resin parts.

Precaution for Use

(1) Storage

To avoid the moisture penetration, we recommend storing LED in a dry box with a desiccant . The recommended storage temperature range is 5°C to 30°C and a maximum humidity of RH50%.

(2) Use Precaution after Opening the Packaging

Use SMD techniques properly when solder the LED as separation of the lens may affect the light output efficiency.

Pay attention to the following:

- a. Recommend conditions after opening the package
 - Sealing / Temperature : 5 ~ 30°C Humidity : less than RH60%
- b. If the package has been opened more than 4 weeks (**MSL 2a**) or the color of the desiccant changes, components should be dried for 10-24hr at 65±5°C

(3) Do not apply mechanical force or excess vibration during the cooling process to normal temperature after soldering.

(4) Do not rapidly cool device after soldering.

(5) Components should not be mounted on warped (non coplanar) portion of PCB.

(6) Radioactive exposure is not considered for the products listed here in.

(7) Gallium arsenide is used in some of the products listed in this publication. These products are dangerous if they are burned or shredded in the process of disposal. It is also dangerous to drink the liquid or inhale the gas generated by such products when chemically disposed of.

(8) This device should not be used in any type of fluid such as water, oil, organic solvent and etc. When washing is required, IPA (Isopropyl Alcohol) should be used.

(9) When the LED are in operation the maximum current should be decided after measuring the package temperature.

(10) The appearance and specifications of the product may be modified for improvement without notice.

(11) Long time exposure of sunlight or occasional UV exposure will cause lens discoloration.

Precaution for Use

(12) VOCs (Volatile organic compounds) emitted from materials used in the construction of fixtures can penetrate silicone encapsulants of LED and discolor when exposed to heat and photonic energy. The result can be a significant loss of light output from the fixture. Knowledge of the properties of the materials selected to be used in the construction of fixtures can help prevent these issues.

(13) Attaching LEDs, do not use adhesives that outgas organic vapor.

(14) The driving circuit must be designed to allow forward voltage only when it is ON or OFF. If the reverse voltage is applied to LED, migration can be generated resulting in LED damage.

(15) LED is sensitive to Electro-Static Discharge (ESD) and Electrical Over Stress (EOS). Below is a list of suggestions that Seoul Semiconductor purposes to minimize these effects.

a. ESD (Electro Static Discharge)

Electrostatic discharge (ESD) is defined as the release of static electricity when two objects come into contact. While most ESD events are considered harmless, it can be an expensive problem in many industrial environments during production and storage. The damage from ESD to an LED may cause the product to demonstrate unusual characteristics such as:

- Increase in reverse leakage current lowered turn-on voltage
- Abnormal emissions from the LED at low current

The following recommendations are suggested to help minimize the potential for an ESD event.

One or more recommended work area suggestions:

- Ionizing fan setup
- ESD table/shelf mat made of conductive materials
- ESD safe storage containers

One or more personnel suggestion options:

- Antistatic wrist-strap
- Antistatic material shoes
- Antistatic clothes

Environmental controls:

- Humidity control (ESD gets worse in a dry environment)

Precaution for Use

b. EOS (Electrical Over Stress)

Electrical Over-Stress (EOS) is defined as damage that may occur when an electronic device is subjected to a current or voltage that is beyond the maximum specification limits of the device. The effects from an EOS event can be noticed through product performance like:

- Changes to the performance of the LED package
(If the damage is around the bond pad area and since the package is completely encapsulated the package may turn on but flicker show severe performance degradation.)
- Changes to the light output of the luminaire from component failure
- Components on the board not operating at determined drive power

Failure of performance from entire fixture due to changes in circuit voltage and current across total circuit causing trickle down failures. It is impossible to predict the failure mode of every LED exposed to electrical overstress as the failure modes have been investigated to vary, but there are some common signs that will indicate an EOS event has occurred:

- Damaged may be noticed to the bond wires (appearing similar to a blown fuse)
- Damage to the bond pads located on the emission surface of the LED package
(shadowing can be noticed around the bond pads while viewing through a microscope)
- Anomalies noticed in the encapsulation and phosphor around the bond wires.
- This damage usually appears due to the thermal stress produced during the EOS event.

c. To help minimize the damage from an EOS event Seoul Semiconductor recommends utilizing:

- A surge protection circuit
- An appropriately rated over voltage protection device
- A current limiting device



Company Information

Published by

Seoul Semiconductor © 2013 All Rights Reserved.

Company Information

Seoul Semiconductor (www.SeoulSemicon.com) manufactures and packages a wide selection of light emitting diodes (LEDs) for the automotive, general illumination/lighting, Home appliance, signage and back lighting markets. The company is the world's fifth largest LED supplier, holding more than 10,000 patents globally, while offering a wide range of LED technology and production capacity in areas such as "nPola", "Acrich", the world's first commercially produced AC LED, and "Acrich MJT - Multi-Junction Technology" a proprietary family of high-voltage LEDs.

The company's broad product portfolio includes a wide array of package and device choices such as Acrich and Acirch2, high-brightness LEDs, mid-power LEDs, side-view LEDs, and through-hole type LEDs as well as custom modules, displays, and sensors.

Legal Disclaimer

Information in this document is provided in connection with Seoul Semiconductor products. With respect to any examples or hints given herein, any typical values stated herein and/or any information regarding the application of the device, Seoul Semiconductor hereby disclaims any and all warranties and liabilities of any kind, including without limitation, warranties of non-infringement of intellectual property rights of any third party. The appearance and specifications of the product can be changed to improve the quality and/or performance without notice.