



16-Channel Constant Current LED Driver with Error Detection/ Power Saving Mode/ Current Gain

Features

- 16 constant-current output channels
Constant output current range: 3~45mA
 - 3~45mA @ 5V supply voltage
 - 3~30mA @ 3.3V supply voltage
 - 3~25mA @ 5V/3.3V supply voltage in mSSOP(GM) package
- Compulsory error detection
 - Data-independent full panel detection
 - Error detection current: small current during 700ns
 - Programmable detection current
 - Individual LED open- and short-circuit detection
 - Leakage and short to ground diagnosis
 - Pre-settable threshold voltage for short-circuit detection and leakage diagnosis
 - Thermal protection
- Power saving modes to reduce supply current of LED driver to 150uA
 - 0-Power mode
- Excellent output current accuracy,
 - Between channels: $<\pm 2.5\%$ (max);
 - Between ICs: $<\pm 3\%$ (max)
- Fast response to achieve uniform output current,
OE (min.): 40ns ($V_{DD}=5V$, $I_{OUT}=20mA$)
- Staggered delay of output, preventing from current surge
- 30MHz clock frequency
- Schmitt trigger input
- Package MSL Level : 3

Small Outline Package

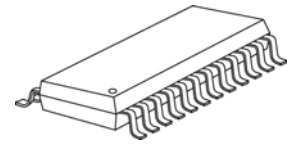

GF: SOP24L-300-1.00

Shrink SOP

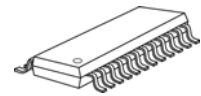

GP: SSOP24L-150-0.64

Mini SSOP

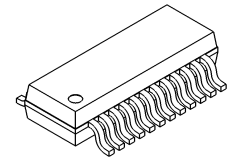

GM: mSSOP24L-100-0.5

Applications

- LED traffic signs
- LED message signs

MBI5038 16-Channel Constant Current LED Driver with Error Detection/ Power Saving Mode/ Current Gain

Product Description

MBI5038 is an enhanced 16-channel constant current LED sink driver with advanced error detection functions and the smart power-saving mode.

MBI5038 provides “compulsory silent error detection”. Once the dedicated command is issued, all of the current output ports will be turned on in about 700ns interval with small current. The image will not be impacted since the turn-on duration and current are so small. MBI5038 may detect all of the current output ports and report the LED error status without comparing original data. Moreover, the settable threshold voltages for short-circuit detection and leakage diagnosis may comply with the variation of different LED forward voltage. Additionally, to ensure the system reliability, MBI5038 is built with thermal error flag to prevent IC from over temperature (160°C).

MBI5038 also features the power saving mode: 0-Power mode. This mode reduces I_{DD} of MBI5038 to 150uA to save the power. For the power saving purposes, MBI5038 is especially designed to save the supply current of LED drivers when most LEDs on LED traffic signs and message signs are usually turned off.

In addition, MBI5038 also allows users to adjust the output current level by setting a programmable configuration code. The code is sent into MBI5038 via the pin SDI. The falling edge of LE would latch the code in the shift register into a built-in 16-bit configuration register, instead of the output latch. The gain code would affect the voltage at the terminal R_{EXT} and control the output current regulator. The output current can be adjusted finely by a gain ranging from 12.5% to 200% in 64 steps.

MBI5038**16-Channel Constant Current LED Driver with****Error Detection/ Power Saving Mode/ Current Gain**

Pin Configuration

GND	1	24	VDD
SDI	2	23	R-EXT
CLK	3	22	SDO
LE	4	21	$\overline{\text{OE}}$
$\overline{\text{OUT0}}$	5	20	$\overline{\text{OUT15}}$
$\overline{\text{OUT1}}$	6	19	$\overline{\text{OUT14}}$
$\overline{\text{OUT2}}$	7	18	$\overline{\text{OUT13}}$
$\overline{\text{OUT3}}$	8	17	$\overline{\text{OUT12}}$
$\overline{\text{OUT4}}$	9	16	$\overline{\text{OUT11}}$
$\overline{\text{OUT5}}$	10	15	$\overline{\text{OUT10}}$
$\overline{\text{OUT6}}$	11	14	$\overline{\text{OUT9}}$
$\overline{\text{OUT7}}$	12	13	$\overline{\text{OUT8}}$

MBI5038GF/GP/GM

Terminal Description

Pin Name	Function
GND	Ground terminal for control logic and current sinks
SDI	Serial-data input to the shift register
CLK	Clock input terminal used to shift data on rising edge and carries command information when LE is asserted.
LE	Data strobe terminal and control command with CLK for extended functions
$\overline{\text{OUT0}} \sim \overline{\text{OUT15}}$	Constant current output ports
$\overline{\text{OE}}$	Enable output ports to sink current. When its level is low (active), the output ports are enabled; when high, all output ports are turned OFF (blanked).
SDO	Serial-data output to the following SDI of the next driver IC
R-EXT	Input terminal used for connecting an external resistor in order to set up the current level of all output ports
VDD	3.3 / 5V supply voltage terminal

MBI5038 16-Channel Constant Current LED Driver with Error Detection/ Power Saving Mode/ Current Gain

Equivalent Circuits of Inputs and Outputs

\overline{OE} Terminal

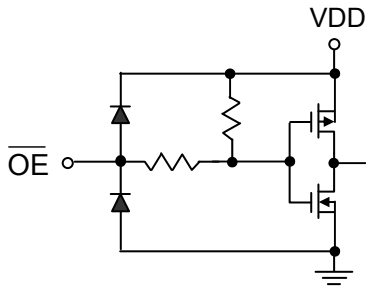

LE Terminal

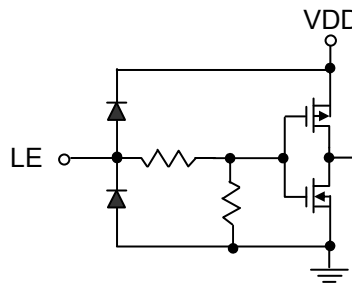

CLK, SDI Terminal

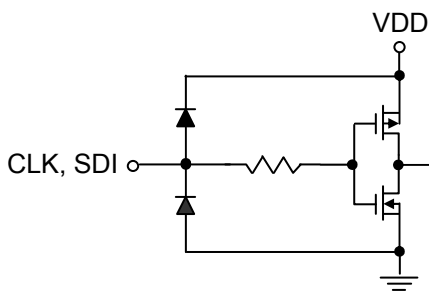

SDO Terminal

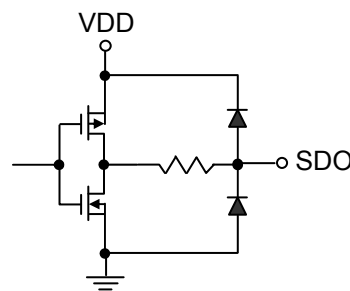

MBI5038

16-Channel Constant Current LED Driver with
Error Detection/ Power Saving Mode/ Current Gain

Maximum Ratings

Characteristic		Symbol	Rating	Unit
Supply Voltage		V_{DD}	0~7.0	V
Sustaining Voltage at SDI, \overline{OE} , LE, CLK Pins		V_{IN}	-0.4 ~ $V_{DD} + 0.4$	V
Sustaining Voltage at CKO, SDO Pins		V_{OUT}	-0.4~ $V_{DD}+0.4$	V
Sustaining Voltage at \overline{OUTn} Pins		V_{DS}	-0.5~17	V
Output Current ($\overline{OUT0} \sim \overline{OUT15}$)		I_{OUT}	+50	mA
GND Terminal Current		I_{GND}	800	mA
Power Dissipation (On 4 Layer PCB, $T_a=25^\circ\text{C}$)*	GF Type	P_D	2.36	W
	GP Type		1.79	
	GM Type		1.34	
Thermal Resistance (On 4 Layer PCB, $T_a=25^\circ\text{C}$)*	GF Type	$R_{th(j-a)}$	53	$^\circ\text{C/W}$
	GP Type		70	
	GM Type		93.5	
Junction Temperature		$T_{j,max}$	150**	$^\circ\text{C}$
Operating Ambient Temperature		T_{opr}	-40 ~ +85	$^\circ\text{C}$
Storage Temperature		T_{stg}	-55 ~ +150	$^\circ\text{C}$
ESD Rating	Human Body Mode (MIL-STD-883G Method 3015.8)	HBM	Class 3A (4.5KV)	-
	Machine Mode (ANSI/ ESD S5.2-2009)	MM	Class M4 (450V)	-

*The PCB size is 76.2mm*114.3mm in simulation. Please refer to JEDEC JESD51.

** Operation at the maximum rating for extended periods may reduce the device reliability; therefore, the suggested operation temperature of the device is under 125 $^\circ\text{C}$.

Note: The performance of thermal dissipation is strongly related to the size of thermal pad, thickness and layer numbers of the PCB. The empirical thermal resistance may be different from simulative value. User should plan for expected thermal dissipation performance by selecting package and arranging layout of the PCB to maximize the capability.

MBI5038 16-Channel Constant Current LED Driver with Error Detection/ Power Saving Mode/ Current Gain

Electrical Characteristics ($V_{DD}=5.0V$; $T_a=25^{\circ}C$)

Characteristics		Symbol	Condition	Min.	Typ.	Max.	Unit	
Supply Voltage		V_{DD}	That assures the IC works properly	4.5	5.0	5.5	V	
Sustaining Voltage at OUT Ports		V_{DS}	$\overline{OUT0} \sim \overline{OUT15}$	-	-	17.0	V	
Output Current		I_{OUT}	Refer to "Test Circuit for Electrical Characteristics"	3	-	45	mA	
		I_{OH}	SDO, $V_{OH}=4.6V$	-	-	-1.0	mA	
		I_{OL}	SDO, $V_{OL}=0.4V$	-	-	1.0	mA	
Input Voltage	"H" level	V_{IH}	$T_a=-40\sim 85^{\circ}C$	$0.7 \times V_{DD}$	-	V_{DD}	V	
	"L" level	V_{IL}	$T_a=-40\sim 85^{\circ}C$	GND	-	$0.3 \times V_{DD}$	V	
Output Leakage Current		I_{OH}	$V_{DS}=17.0V$ and all channels off	-	-	0.1	μA	
Output Voltage	SDO	V_{OL}	$I_{OL}=+1.0mA$	$V_{DD}-0.4$	-	0.4	V	
		V_{OH}	$I_{OH}=-1.0mA$	4.6	-	-	V	
Current Skew (Channel)		dI_{OUT1}/I_{OUT}	$I_{OUT}=20mA$ $V_{DS}=1.0V$	$R_{ext}=700\Omega$	-	± 1.5	± 2.5	%
Current Skew (IC)		dI_{OUT2}/I_{OUT}	$I_{OUT}=20mA$ $V_{DS}=1.0V$	$R_{ext}=700\Omega$	-	± 1.5	± 3.0	%
Output Current vs. Output Voltage Regulation*		$\%/dV_{DS}$	V_{DS} within 1.0V and 3.0V, $R_{ext}=700\Omega@20mA$	-	± 0.1	± 0.3	% / V	
Output Current vs. Supply Voltage Regulation*		$\%/dV_{DD}$	V_{DD} within 4.5V and 5.5V	-	± 1.0	± 2.0	% / V	
Open-Circuit Detection Threshold Voltage**		$V_{OD,TH}$	-	-	-	0.30	V	
Leakage Current & Short to Ground Diagnosis Threshold		$V_{LEAK,TH}$	Programmable by configuration register	1.4 1.8 2.2 2.9	$0.4 \times V_{DD}$ $0.5 \times V_{DD}$ $0.6 \times V_{DD}$ $0.7 \times V_{DD}$	-	V	
LED Short-circuit Detection Threshold		$V_{SHORT,TH}$	Programmable by configuration register	2.3 2.8 3.8 4.3	2.5 3.0 4.0 4.5	-	V	
Pull-down Resistor		$R_{IN(down)}$	LE	250	500	800	K Ω	
Pull-up Resistor		$R_{IN(up)}$	\overline{OE}	250	500	800	K Ω	
Supply Current	"Off"	$I_{DD(off) 1}$	$R_{ext}=\text{Open}, \overline{OUT0} \sim \overline{OUT15} =\text{Off}$	-	2.0	4.0	mA	
		$I_{DD(off) 2}$	$R_{ext}=6K\Omega, \overline{OUT0} \sim \overline{OUT15} =\text{Off}$	-	4	6	mA	
		$I_{DD(off) 3}$	$R_{ext}=680\Omega, \overline{OUT0} \sim \overline{OUT15} =\text{Off}$	-	6	8	mA	
	"On"	$I_{DD(on) 1}$	$R_{ext}=6K\Omega, \overline{OUT0} \sim \overline{OUT15} =\text{On}$	-	4	6	mA	
		$I_{DD(on) 2}$	$R_{ext}=680\Omega, \overline{OUT0} \sim \overline{OUT15} =\text{On}$	-	6.0	8.0	mA	
	0-Power mode	$I_{DD(0-Power)}$	-	-	100	150	μA	
Thermal Flag Temperature 1		T_{TF1}	Junction Temperature	-	140	-	$^{\circ}C$	
Thermal Flag Temperature 2		T_{TF2}	Junction Temperature	-	160	-	$^{\circ}C$	

*One channel on.

MBI5038

16-Channel Constant Current LED Driver with

Error Detection/ Power Saving Mode/ Current Gain

Electrical Characteristics ($V_{DD}=3.3V$; $T_a=25^\circ C$)

Characteristics		Symbol	Condition	Min.	Typ.	Max.	Unit	
Supply Voltage		V_{DD}	That assures the IC works properly	3.0	3.3	3.6	V	
Sustaining Voltage at OUT Ports		V_{DS}	$\overline{OUT0} \sim \overline{OUT15}$	-	-	17.0	V	
Output Current		I_{OUT}	Refer to "Test Circuit for Electrical Characteristics"	3	-	30	mA	
		I_{OH}	SDO, $V_{OH}=2.9V$	-	-	-1.0	mA	
		I_{OL}	SDO, $V_{OL}=0.4V$	-	-	1.0	mA	
Input Voltage	"H" level	V_{IH}	$T_a=-40\sim 85^\circ C$	$0.7 \times V_{DD}$	-	V_{DD}	V	
	"L" level	V_{IL}	$T_a=-40\sim 85^\circ C$	GND	-	$0.3 \times V_{DD}$	V	
Output Leakage Current		I_{OH}	$V_{DS}=17.0V$ and all channels off	-	-	0.1	μA	
Output Voltage	SDO	V_{OL}	$I_{OL}=+1.0mA$	$V_{DD}-0.4$	-	0.4	V	
		V_{OH}	$I_{OH}=-1.0mA$	2.9	-	-	V	
Current Skew (Channel)		dl_{OUT1}/I_{OUT}	$I_{OUT}=20mA$ $V_{DS}=1.0V$	$R_{ext}=700\Omega$	-	± 1.5	± 2.5	%
Current Skew (IC)		dl_{OUT2}/I_{OUT}	$I_{OUT}=20mA$ $V_{DS}=1.0V$	$R_{ext}=700\Omega$	-	± 1.5	± 3.0	%
Output Current vs. Output Voltage Regulation*		$\%/dV_{DS}$	V_{DS} within 1.0V and 3.0V, $R_{ext}=7500\Omega@20mA$	-	± 0.1	± 0.3	% / V	
Output Current vs. Supply Voltage Regulation*		$\%/dV_{DD}$	V_{DD} within 3.0V and 3.6V	-	± 1.0	± 2.0	% / V	
Open-Circuit Detection Threshold Voltage**		$V_{OD,TH}$	-	-	-	0.30	V	
Leakage Current & Short to Ground Diagnosis Threshold		$V_{LEAK,TH}$	Programmable by configuration register	0.8 1.0 1.3 1.7	$0.4 \times V_{DD}$ $0.5 \times V_{DD}$ $0.6 \times V_{DD}$ $0.7 \times V_{DD}$	-	V	
LED Short-circuit Detection Threshold		$V_{SHORT,TH}$	Programmable by configuration register	2.3 2.8 3.8 4.3	2.5 3.0 4.0 4.5	-	V	
Pull-down Resistor		$R_{IN(down)}$	LE	250	500	800	K Ω	
Pull-up Resistor		$R_{IN(up)}$	\overline{OE}	250	500	800	K Ω	
Supply Current	"Off"	$I_{DD(off) 1}$	$R_{ext}=\text{Open}, \overline{OUT0} \sim \overline{OUT15} =\text{Off}$	-	2.5	3.0	mA	
		$I_{DD(off) 2}$	$R_{ext}=680\Omega, \overline{OUT0} \sim \overline{OUT15} =\text{Off}$	-	5.1	5.6	mA	
		$I_{DD(off) 3}$	$R_{ext}=490\Omega, \overline{OUT0} \sim \overline{OUT15} =\text{Off}$	-	6.6	7.1	mA	
	"On"	$I_{DD(on) 1}$	$R_{ext}=680K\Omega, \overline{OUT0} \sim \overline{OUT15} =\text{On}$	-	5.1	5.6	mA	
		$I_{DD(on) 2}$	$R_{ext}=490K\Omega, \overline{OUT0} \sim \overline{OUT15} =\text{On}$	-	6.6	7.1	mA	
	0-Power mode	$I_{DD(0-Power)}$	-	-	100	150	μA	
Thermal Flag Temperature 1		T_{TF1}	Junction Temperature	-	-	140	$^\circ C$	
Thermal Flag Temperature 2		T_{TF2}	Junction Temperature	-	-	160	$^\circ C$	

*One channel on

MBI5038 16-Channel Constant Current LED Driver with Error Detection/ Power Saving Mode/ Current Gain

Test Circuit for Electrical Characteristics

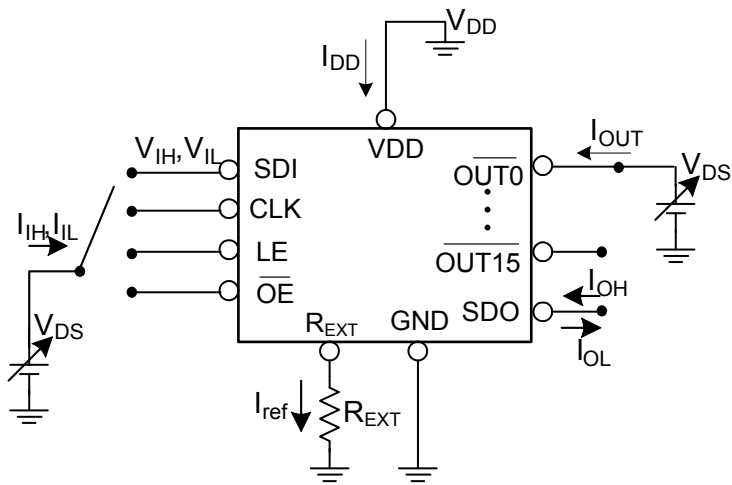

MBI5038 16-Channel Constant Current LED Driver with Error Detection/ Power Saving Mode/ Current Gain Switching Characteristics ($V_{DD}=5.0V$; $T_a=25^\circ C$)

Characteristics		Symbol	Condition	Min.	Typ.	Max.	Unit
Setup Time	SDI - CLK \uparrow	t_{SU0}	$V_{DD}=5.0V$ $V_{IH}=V_{DD}$ $V_{IL}=GND$ $R_{ext}=680\Omega$ $V_{DS}=1V$ $R_L=150\Omega$ $C_L=10pF$ $C_1=100nF$ $C_2=10\mu F$ $C_{SDO}=10pF$ $V_{LED}=4.0V$	7	-	-	ns
	LE \uparrow - CLK \uparrow	t_{SU1}		7	-	-	ns
	LE \downarrow - CLK \uparrow	t_{SU2}		50	-	-	ns
Hold Time	CLK \uparrow - SDI	t_{H0}		7	-	-	ns
	CLK \uparrow - LE \downarrow	t_{H1}		7	-	-	ns
	LE \downarrow - \overline{OE} \uparrow	t_{H2}		10	-	-	ns
Propagation Delay Time	CLK - SDO	t_{PD0}		-	25	33	ns
	\overline{OE} - $\overline{OUT2r}^*$	t_{PD1}		-	25	-	ns
	LE - SDO	t_{PD2}^{**}		-	30	40	ns
Staggered Delay of Output	$\overline{OUT2n+1}^{***}$	t_{DL1}		-	2	-	ns
Pulse Width	LE	$t_{w(L)}$		15	-	-	ns
	CLK	$t_{w(CLK)}$		25	-	-	ns
	\overline{OE}	$t_{w(OE)}$		40	-	-	ns
SDO Rise Time		$t_{r,SDO}$		-	10	-	ns
SDO Fall Time		$t_{f,SDO}$		-	10	-	ns
Output Rise Time of Output Ports	High speed	t_{OR}	-	15	25	ns	
	Low speed		-	35	60	ns	
Output Fall Time of Output Ports	High speed	t_{OF}	-	15	25	ns	
	Low speed		-	35	60	ns	
Compulsory Error Detection Operation Time****		t_{ERR-C}	700	-	-	ns	
Data Clock Frequency (Pure Digital)		F_{CLK}	-	-	30	MHz	

*Output waveforms have good uniformity among channels.

** For configuration register read command

***Refer to the Timing Waveform, n=0, 1, 2, 3, 4, 5, 6, 7.

****Users have to leave more time than the maximum error detection time for the error detection.

MBI5038

16-Channel Constant Current LED Driver with

Error Detection/ Power Saving Mode/ Current Gain

Switching Characteristics ($V_{DD}=3.3V$; $T_a=25^{\circ}C$)

Characteristics		Symbol	Condition	Min.	Typ.	Max.	Unit
Setup Time	SDI - CLK \uparrow	t_{SU0}	$V_{DD}=3.3V$ $V_{IH}=V_{DD}$ $V_{IL}=GND$ $R_{ext}=700\Omega$ $V_{DS}=1V$ $R_L=200\Omega$ $C_L=10pF$ $C_1=100nF$ $C_2=10\mu F$ $C_{SDO}=10pF$ $V_{LED}=4.0V$	10	-	-	ns
	LE \uparrow - CLK \uparrow	t_{SU1}		10	-	-	ns
	LE \downarrow - CLK \uparrow	t_{SU2}		10	-	-	ns
Hold Time	CLK \uparrow - SDI	t_{H0}		8	-	-	ns
	CLK \uparrow - LE \downarrow	t_{H1}		8	-	-	ns
	LE \downarrow - \overline{OE} \uparrow	t_{H2}		12	-	-	ns
Propagation Delay Time	CLK - SDO	t_{PD0}		-	30	40	ns
	\overline{OE} - $\overline{OUT2r}^*$	t_{PD1}		-	30	-	ns
	LE - SDO	t_{PD2}^{**}		-	40	50	ns
Staggered Delay of Output	$\overline{OUT2n+1}^{***}$	t_{DL1}		-	2	-	ns
Pulse Width	LE	$t_{w(L)}$		15	-	-	ns
	CLK	$t_{w(CLK)}$		25	-	-	ns
	\overline{OE}	$t_{w(OE)}$		70	-	-	ns
SDO Rise Time		$t_{r,SDO}$	-	10	-	ns	
SDO Fall Time		$t_{f,SDO}$	-	10	-	ns	
Output Rise Time of Output Ports	High speed	t_{OR}	-	25	35	ns	
	Low speed		-	40	50	ns	
Output Fall Time of Output Ports	High speed	t_{OF}	-	25	35	ns	
	Low speed		-	40	50	ns	
Compulsory Error Detection Operation Time****		t_{ERR-C}	700	-	-	ns	
Data Clock Frequency (Pure Digital)		F_{CLK}	-	-	20	MHz	

*Output waveforms have good uniformity among channels

** For configuration register read command

***Refer to the Timing Waveform, n=0, 1, 2, 3, 4, 5, 6, 7

****Users have to leave more time than the maximum error detection time for the error detection.

MBI5038 16-Channel Constant Current LED Driver with Error Detection/ Power Saving Mode/ Current Gain

Test Circuit for Switching Characteristics

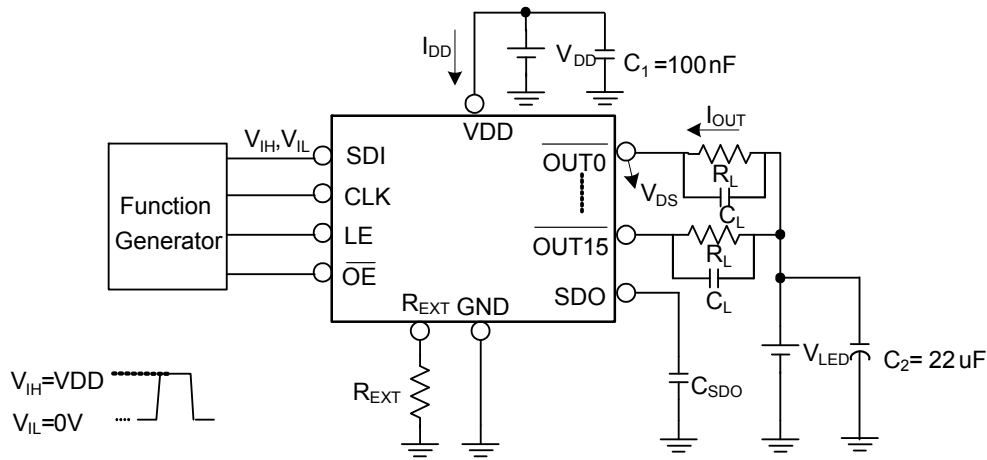

MBI5038

16-Channel Constant Current LED Driver with Error Detection/ Power Saving Mode/ Current Gain

Timing Waveform

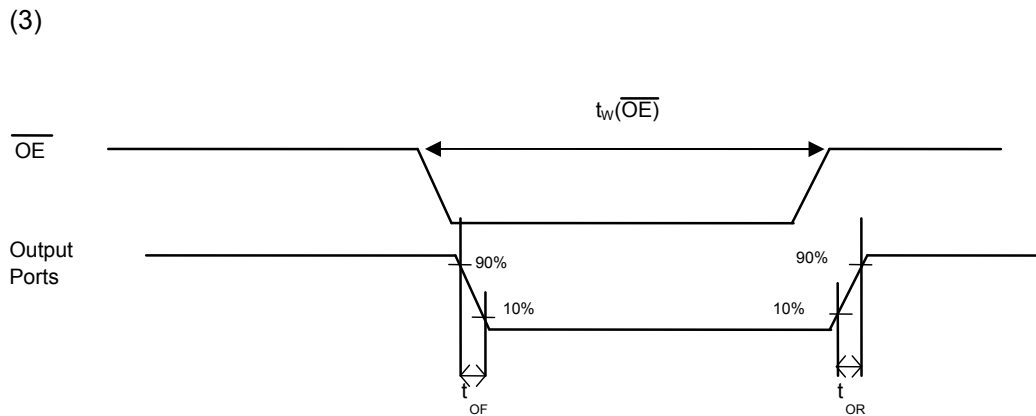
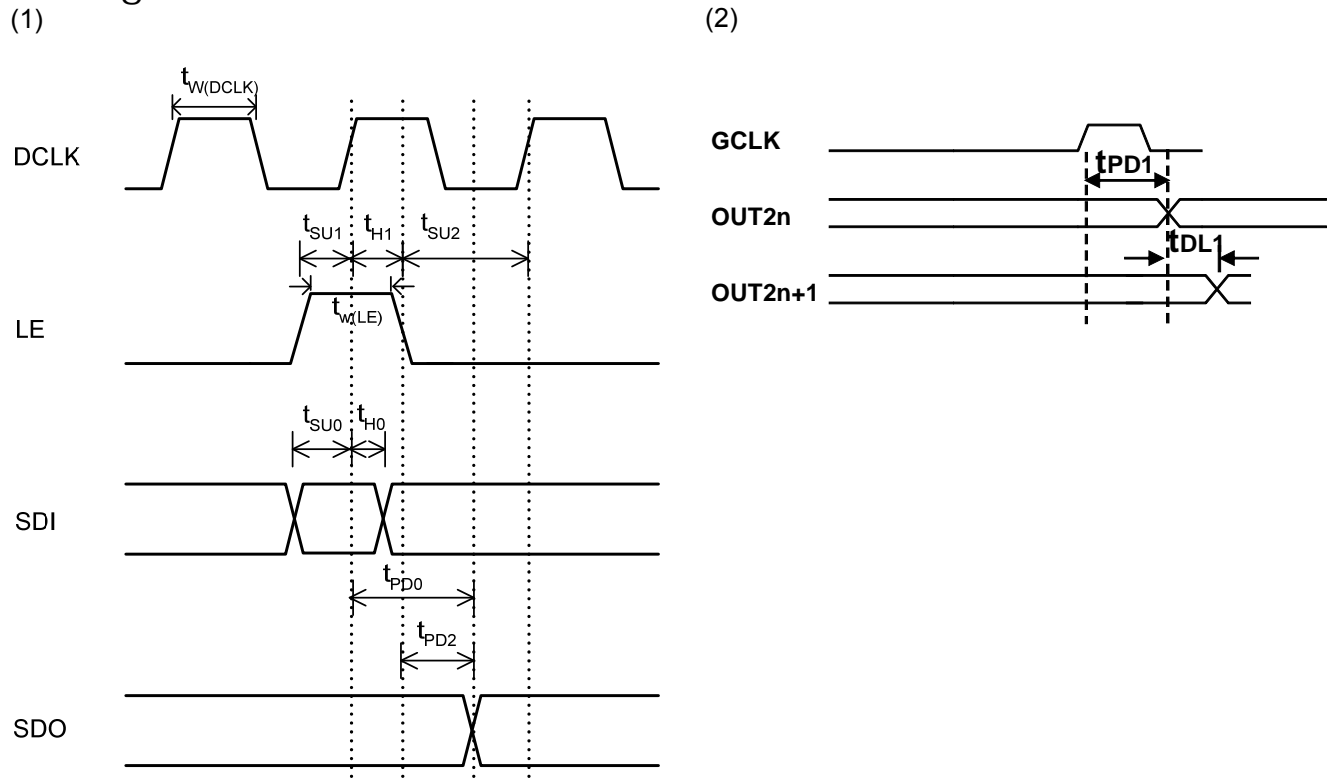

MBI5038 16-Channel Constant Current LED Driver with Error Detection/ Power Saving Mode/ Current Gain

Control the Output Ports

The data are shifted from the SDI to the 16-bit shift register. When the LE is high without CLK toggled, the data in the shift register are latched to the output latch at the falling edge of LE. This is so-called "series-in parallel-out" mechanism.

When the \overline{OE} is low and the data in the output latch are "1", the output channel is turned on and the current sinks into the output port. If LEDs are connected to the output port with adequate power source, the LEDs will be lit up with the pre-set current.

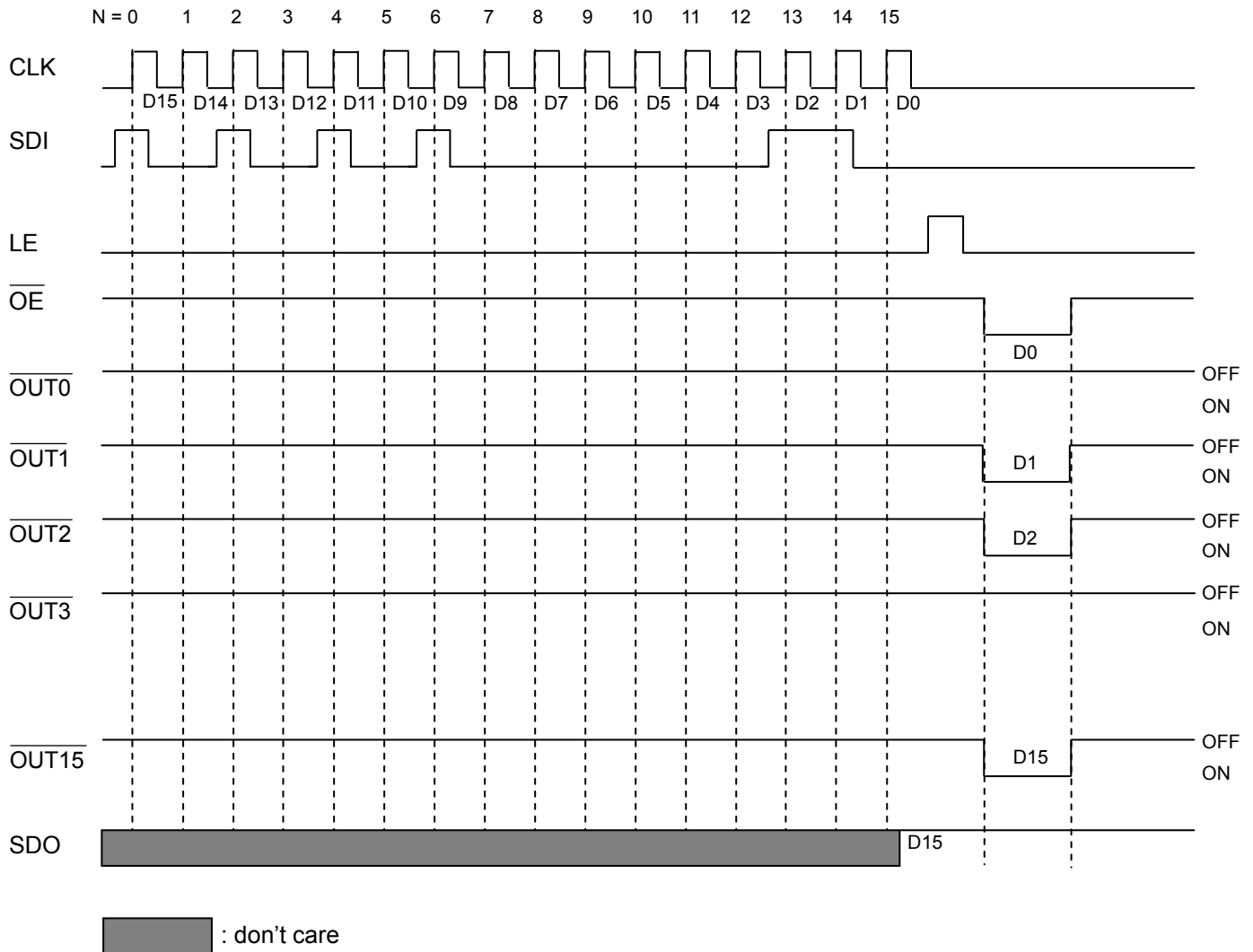

MBI5038 16-Channel Constant Current LED Driver with Error Detection/ Power Saving Mode/ Current Gain

Definition of Configuration Register

MSB

LSB

F	E	D	C	B	A	9	8	7	6	5	4	3	2	1	0
---	---	---	---	---	---	---	---	---	---	---	---	---	---	---	---

e.g. Default Value

F	E	D	C	B	A	9	8	7	6	5	4	3	2	1	0
0	0	11	11	00	0	1	101011								

Bit	Attribute	Definition	Value	Function
F	Read/Write	t_{OR} / t_{OF} speed switch	0	0: high speed 1: low speed
E	Reserved	Reserved	00	Reserved
D~C	Read/Write	Threshold voltage of short-circuit detection	00 01 10 11(Default)	00: 2.5V 01: 3V 10: 4V 11: 4.5V
B~A	Read/Write	Threshold voltage of leakage detection	00 01 10 11(Default)	00: 0.3xVdd 01: 0.4xVdd 10: 0.5xVdd 11: 0.6xVdd
9~8	Reserved	Open/Short current selection	00(Default) 01 10 11	00 : 25uA 01 : 50uA 10 : 100uA 11 : 200uA
7	Read/Write	0-Power mode	0 (Default) 1	Disable 0-power mode Enable 0-power mode
6	Read/Write	Thermal shutdown	0 1(Default)	Disable thermal shutdown. Enable thermal shutdown The threshold is 160°C. All channels will be turned off.
5~0	Read/Write	Output current gain adjustment	000000 ~ 111111	000000:12.5% 101011:100%(Default) 111111:200%

MBI5038 16-Channel Constant Current LED Driver with Error Detection/ Power Saving Mode/ Current Gain Control Command

Command Name	Signals Combination		Description
	LE	Number of CLK rising edge when LE is asserted	The Action after a falling edge of LE
Data Latch	High	0	Serial data are transferred to the buffers
Stop compulsory error detection	High	0	Stop compulsory1/ compulsory2/ compulsory3/ compulsory4 error detection.
Write configuration register	High	4	Write 16-bit configuration register
Read configuration register	High	5	Read the configuration register
Compulsory1 error detection(open error)	High	6	Start compulsory error detection(open error detection)
Compulsory2 error detection(short error)	High	7	Start compulsory error detection(short error detection)
Compulsory3 error detection(R_{ext} -open, the status of thermal protection and the status of 0-power mode)	High	8	Start compulsory error detection(R_{ext} -open error detection, the status of thermal protection and the status of 0-power mode)
Compulsory4 error detection(Leakage or Short to ground diagnosis)	High	9	Start leakage or short to ground diagnosis detection
Enable write configuration (confirm command)	High	12	Enable to write the configuration register
Wake-up	High	13	Wake up from 0-power mode

Note: Number of CLK ≥ 14 no action.

For detailed timing diagrams, please refer to the section of "Principle of Operation".

MBI5038 16-Channel Constant Current LED Driver with Error Detection/ Power Saving Mode/ Current Gain

Write Configuration Register

Write the configuration register when receiving one LE pulse containing 12 CLKs, then send 16-bit configuration setting to each LED driver and send one LE pulse containing 4 CLKs.

write cfg register

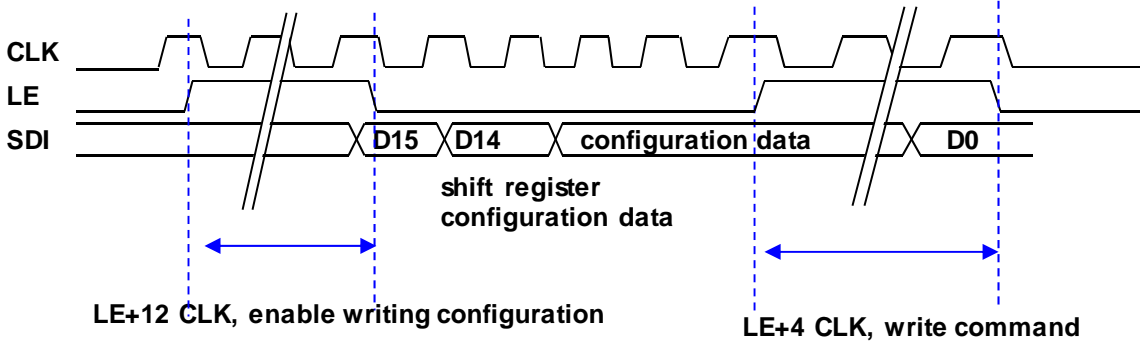

Read Configuration Register

Read the configuration register when receiving one LE pulse containing 5 CLKs to read the configuration setting. After the command, 16-bit configuration of each MBI5038 will be shifted out sequentially from the Nth MBI5038 to the 1st MBI5038.

read cfg register

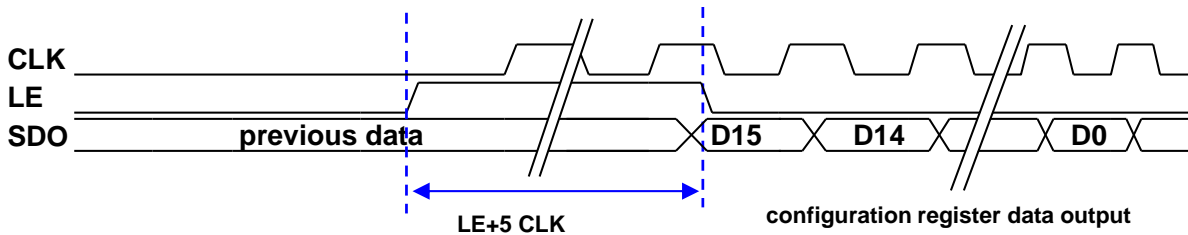

MBI5038 16-Channel Constant Current LED Driver with Error Detection/ Power Saving Mode/ Current Gain

Principle of Operation

Compulsory Error Detection

Compulsory error detection includes open-circuit detection, short-circuit detection, and leakage diagnosis by issuing different control commands.

Compulsory1 Error Detection - LED Open-circuit

MBI5038 will perform compulsory1 error detection when receiving one LE pulse with 6 CLKs and will stop the error detection when receiving one LE pulse with 0 CLK. Besides, the output channels will be forced to turn off to perform the compulsory1 error detection. The duration is suggested longer than 700ns (between the LE falling edges). The error report will be shifted out after the compulsory1 error detection operation time (LE+0 CLK). MBI5038 will shift out open-circuit reports from SDO simultaneously.

Error Code

Detection Result	Error Flag for the Corresponding Channel
LED open error detected in the channel	0
No LED open error detected in the channel	1
MBI5038 enters 0-power mode	1

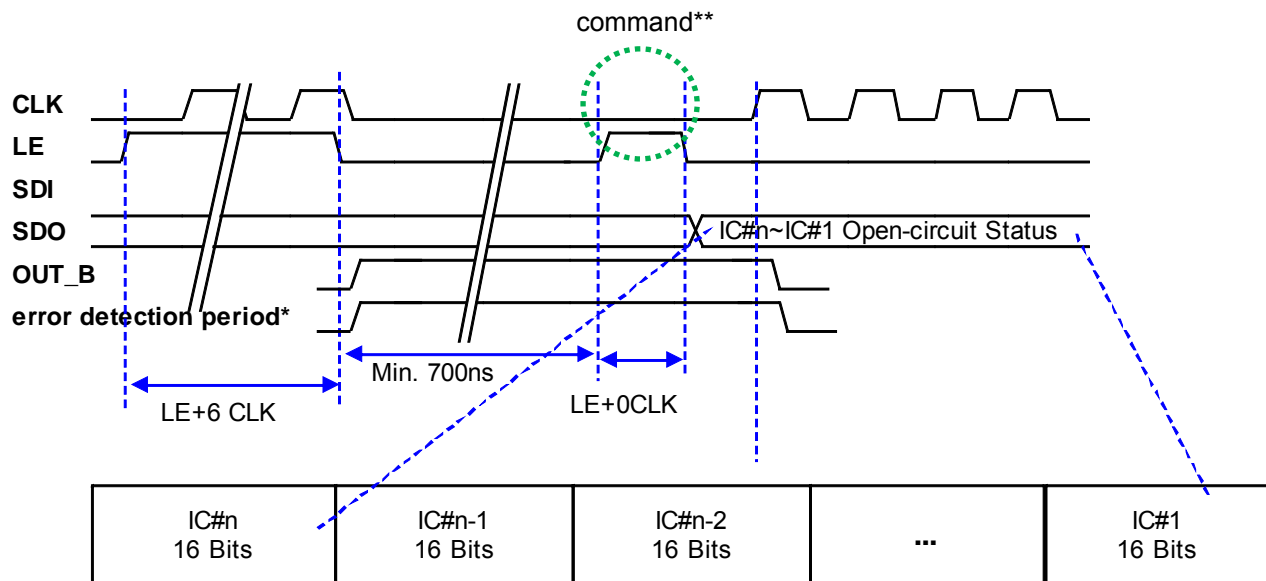

*For the correctness of the error message, MBI5038 releases the error detection period only when receiving one LE pulse containing 0 CLK and CLK is active. During the error detection period, MBI5038 will force OUT_B off and perform the compulsory error detection. MBI5038 releases the error detection period when LE falling (any commands).

**Chip releases the error detection period when LE falling (any commands).

MBI5038 16-Channel Constant Current LED Driver with Error Detection/ Power Saving Mode/ Current Gain Compulsory2 Error Detection - LED Short-circuit

MBI5038 will perform compulsory2 error detection when receiving one LE pulse with 7 CLKs and will stop the error detection when receiving one LE pulse with 0 CLK. The output channels will be forced to turn off and then turn on within a small current of 0.25mA. The duration is suggested longer than 700ns (between the LE falling edges) to perform compulsory2 error detection. The error report will be shifted out after the compulsory2 error detection operation time (LE+ 0 CLK). MBI5038 will shift out short-circuit reports from SDO simultaneously.

Error Code

Detection Result	Error Flag for the Corresponding Channel
LED short error detected in the channel	0
No LED short error detected in the channel	1
MBI5038 enters 0-power mode	1

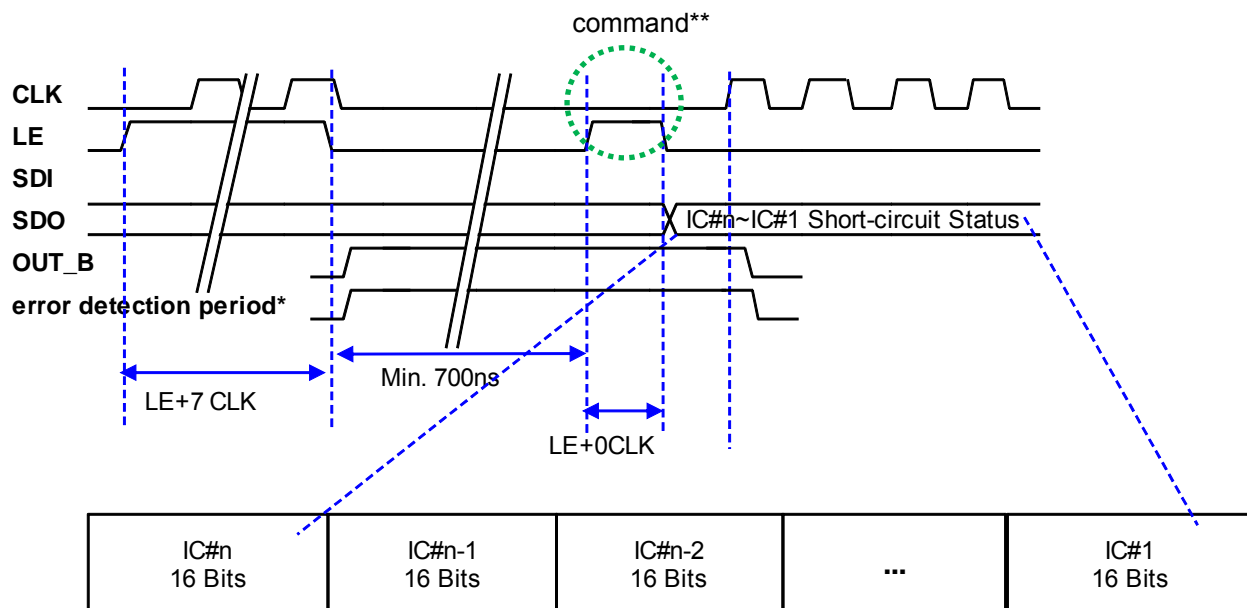

*For the correctness of the error message, MBI5038 releases the error detection period only when receiving one LE pulse containing 0 CLK and CLK is active. During the error detection period, MBI5038 will force OUT_B off and perform the compulsory error detection. MBI5038 releases the error detection period when LE falling (any commands).

** Chip releases the error detection period when LE falling (any commands).

Compulsory3 Error Detection - Fault Status Report

MBI5038 will perform compulsory3 error detection when receiving one LE pulse with 8 CLKs and will stop the error detection when receiving one LE pulse with 0 CLK. Besides, the output channels will be forced to turn off to perform the compulsory3 error detection. The duration is suggested longer than 700ns (between the LE falling edges). The error report will be shifted out after the compulsory3 error detection operation time (LE+0 CLK). MBI5038 will shift out R_{ext}-open, thermal protection error reports, the status of 0-power mode and watchdog timer (WDT) time-out from SDO simultaneously.

MBI5038

16-Channel Constant Current LED Driver with Error Detection/ Power Saving Mode/ Current Gain

0-power Mode

Detection Result	0-power Mode Status
In 0-power Mode	1
Out of 0-power mode	0

Error Code

Detection Result	Error Flag for the Corresponding Chip
R _{ext} open-circuit detected	0
No R _{ext} open-circuit detected	1

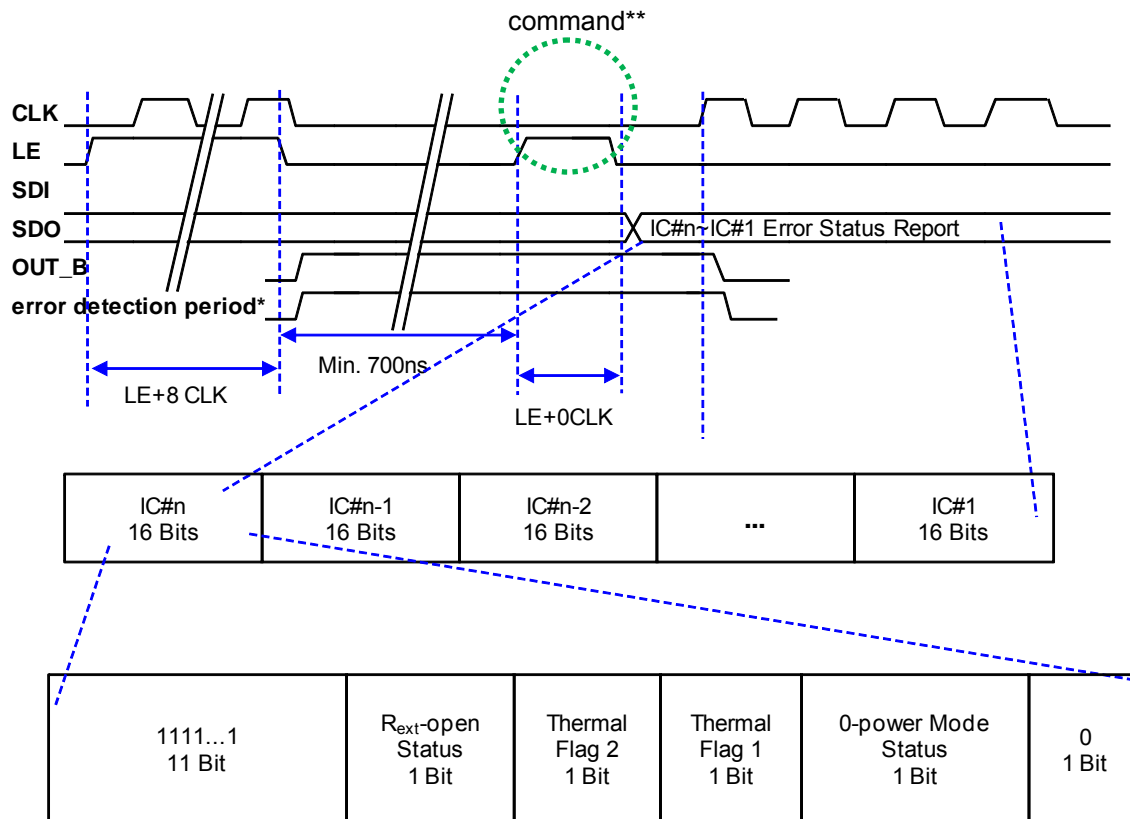

*For the correctness of the error message, MBI5038 releases the error detection period only when receiving one LE pulse containing 0 CLK and CLK is active. During the error detection period, MBI5038 will force OUT_B off and perform the compulsory error detection. MBI5038 releases the error detection period when LE falling (any commands).

** Chip releases the error detection period when LE falling (any commands).

Thermal Flag

Thermal flag 1 is over-temperature alarm, and thermal flag 2 is thermal shutdown. When the IC temperature is over 140°C, thermal flag 1 will report “0”. When the IC temperature is under 120°C, thermal flag 1 will recover to “1”. When the IC temperature is over 160°C, the thermal flag 2 will become “0”, and the output channels will be shut down. The thermal shutdown status is latched until power cycling or a wakeup command issued from the controller.

MBI5038 16-Channel Constant Current LED Driver with Error Detection/ Power Saving Mode/ Current Gain Compulsory4 Error Detection - Device Leakage Diagnosis

MBI5038 will perform compulsory4 error detection when receiving one LE pulse with 9 CLKs and will stop the error detection when receiving one LE pulse with 0 CLK. Besides, the output channels will be forced to turn off and then turn on within a small current of 0.4uA. The duration is suggested longer than 700ns (between the LE falling edges) to perform compulsory4 error detection. The error report will be shifted out after the compulsory4 error detection operation time (LE+ 0 CLK). MBI5038 will shift out leakage error reports from SDO simultaneously.

Error Code

Detection Result	Error Flag for the Corresponding Channel
Leakage error detected in the channel	0
No leakage error detected in the channel	1
MBI5038 enters 0-power mode	1

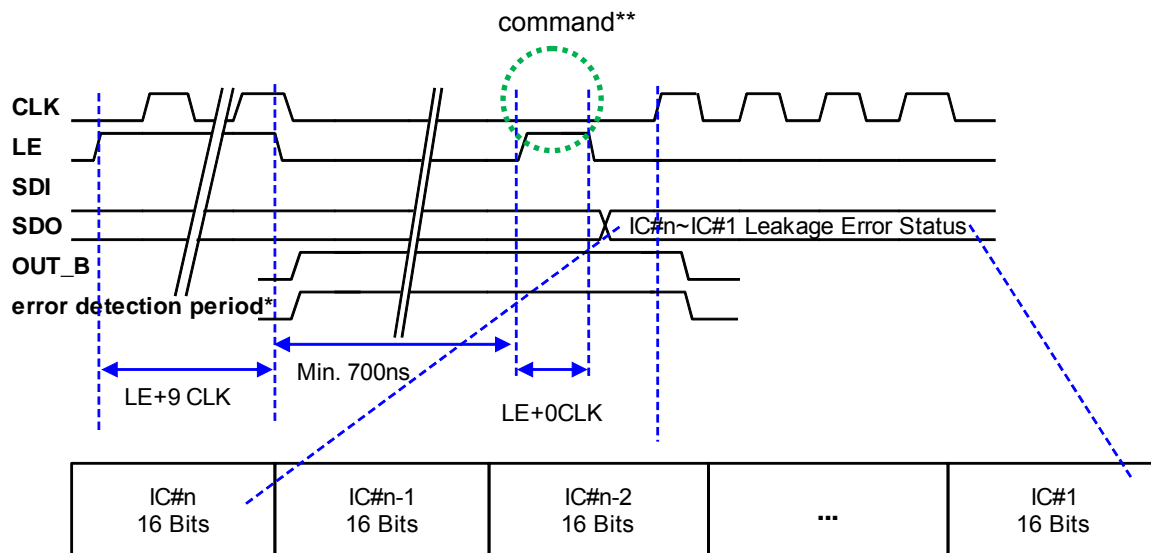

*For the correctness of the error message, MBI5038 releases the error detection period only when receiving one LE pulse containing 0 CLK and CLK is active. During the error detection period, MBI5038 will force OUT_B off and perform the compulsory error detection. MBI5038 releases the error detection period when LE falling (any commands).

** Chip releases the error detection period when LE falling (any commands).

Setting the threshold voltage for short-circuit detection

Users can set the threshold voltage ($V_{SD,TH}$) for compulsory short-circuit detection by bit [C:B] of configuration register as summarized below:

- 00: 2.5V
- 01: 3V
- 10: 4V
- 11: 4.5V (default)

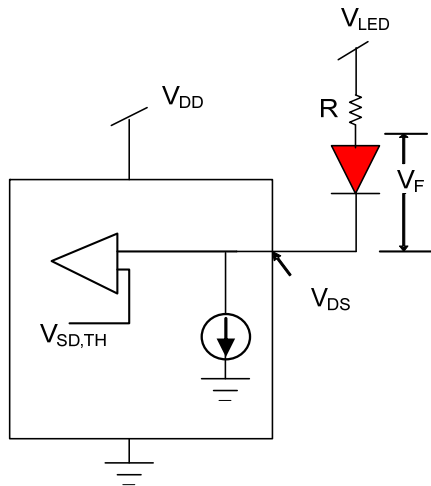
MBI5038**16-Channel Constant Current LED Driver with****Error Detection/ Power Saving Mode/ Current Gain**

MBI5038 provides settable $V_{\text{SHORT.TH}}$ for different LED configuration. If the detected voltage is larger than $V_{\text{SHORT.TH}}$, the chip identifies the LED as short-circuit. For example, if each output channel of this chip drives one red LED, the $V_{\text{SHORT.TH}}$ should be set smaller. If each output channel of this chip drives several white LEDs, the $V_{\text{SHORT.TH}}$ should be set larger. The system should be considered the accumulated V_F of the LEDs when setting a suitable $V_{\text{SHORT.TH}}$.

Thermal Protection

Users can set the thermal protection by bit “6” of configuration register. To enable the thermal shutdown function, the bit “6” is set to “1” (default). To disable the thermal shutdown function, the bit “6” is set to “0”.

This chip provides two thermal flags:

Thermal flag 1 is over-temperature alarm, and thermal flag 2 is thermal shutdown. When the IC temperature is over 140°C, thermal flag 1 will report “0”. When the IC temperature is under 120°C, thermal flag 1 will recover to “1”.

When the IC temperature is over 160°C, the thermal flag 2 will become “0” and this chip will turn off the output current of all channels automatically. It will not turn on the output channels until power cycling or a wakeup command issued from the controller.

0-power Mode

By setting bit “7” of the configuration register, the 0-power mode of this chip will be effective. When all the output data of this chip are “0”, MBI5038 will enter the 0-power mode automatically. When the non-zero data is latched, this chip will leave 0-power mode automatically. Users may also force this chip to leave the 0-power mode by command. The output recovery time from 0-power mode is 0.96ms typically.

To optimize the power saving of the 0-power mode, it is recommended to categorize LEDs along with LED drivers into groups when designing PCBs in order to allow this chip to turn on or turn off the cascaded LEDs in the group simultaneously. Therefore, the 0-power mode of this chip is especially useful for LED message signs to save the power of LED drivers since many LEDs of an LED message sign are usually not in use.

When 0-power mode is enabled, all error detection commands (open-circuit, short-circuit, leakage, thermal detection, R_{ext} -open) will not perform and return to “1”, but the other commands (write and read configurations) are still active.

MBI5038

16-Channel Constant Current LED Driver with

Error Detection/ Power Saving Mode/ Current Gain

Automatically enter and leave the 0-Power mode

Automatically enter the 0-power saving mode when PWM gray scale data are all zero. In 0-power saving mode, the output is turn off.

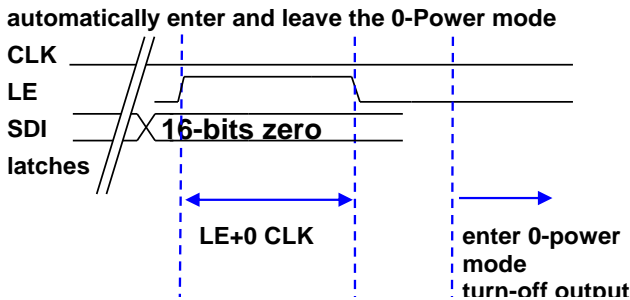

Until the PWM gray scale data are all none zero and must wait 1 min-second, the output will be turn on and automatically leave the 0-Power mode.

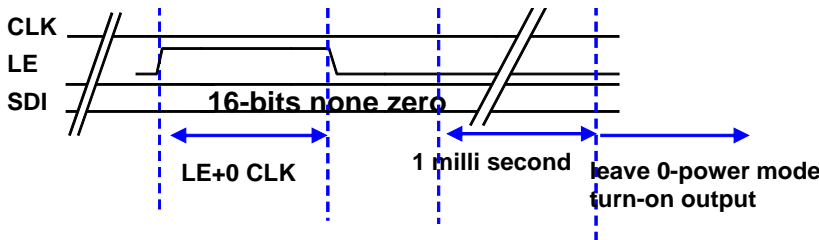

Enter the 0-power mode automatically but leave by the command

Automatically enter the 0-power saving mode when PWM gray scale data are all zero. In 0-power saving mode, the output is turn off. Until the wake up command is executed and must wait 1 milli second, the output will be turn on and leave the 0-Power mode.

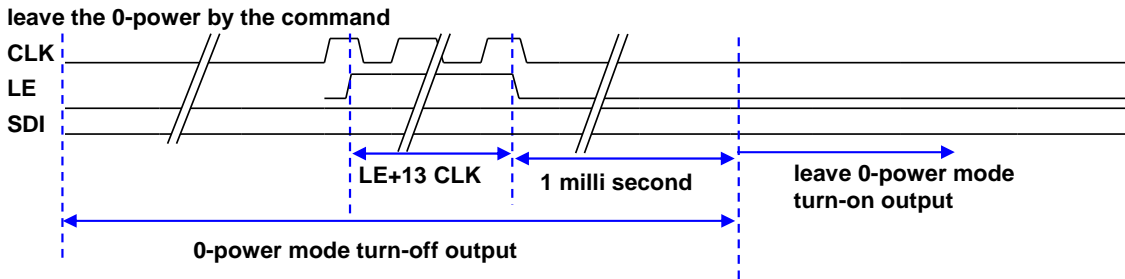

MBI5038 16-Channel Constant Current LED Driver with Error Detection/ Power Saving Mode/ Current Gain Constant Current

In LED display applications, MBI5038 provides nearly no current variations from channel to channel and from IC to IC. This can be achieved by:

- 1) While $I_{OUT} \leq 80\text{mA}$, the maximum current skew between channels is less than $\pm 1.5\%$ (typical) and that between ICs is less than $\pm 3\%$ (typical).
- 2) In addition, the characteristics curve of output stage in the saturation region is flat and users can refer to the figure as shown below. Thus, the output current can be kept constant regardless of the variations of LED forward voltages (V_f). The output current level in the saturation region is defined as output target current $I_{out,target}$.

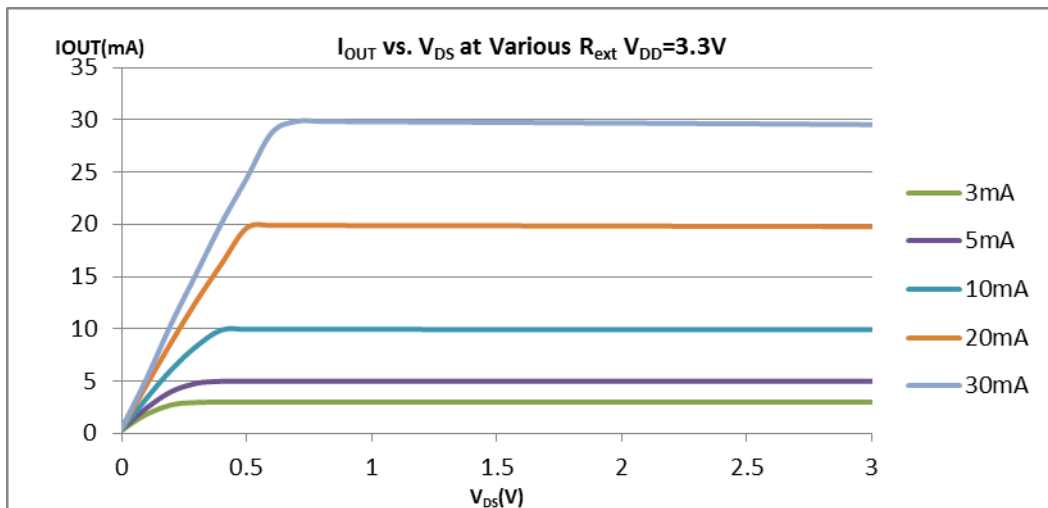
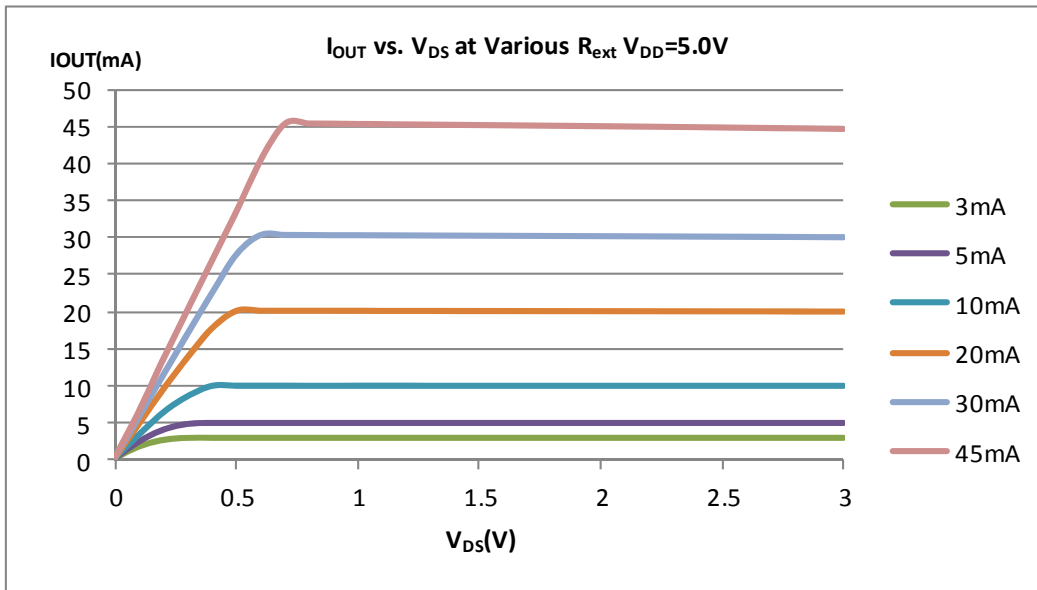

MBI5038**16-Channel Constant Current LED Driver with****Error Detection/ Power Saving Mode/ Current Gain****Setting Output Current**

The output current (I_{OUT}) is set by an external resistor, R_{ext} . The default relationship between I_{OUT} and R_{ext} is shown in the following figure.

Also, the output current can be calculated from the equation:

$$V_{R-EXT}=0.61 \text{ Volt} \times G \times H; I_{OUT}=V_{R-EXT}/ (R_{ext} \times H) \times 23.0$$

HC=1=>H=1 (Please refers to Current Gain Adjustment section on next page for "HC" description)

HC=0=>H=4

Whereas R_{ext} is the resistance of the external resistor connected to R-EXT terminal and V_{R-EXT} is its voltage. G is the digital current gain, which is set by the bit5 – bit0 of the configuration register. The default value of G is 12.5%. For your information, the output current is about 3mA when $R_{ext}=575\Omega$ if G is set to default value 12.5%. The formula and setting for G are described in next section.

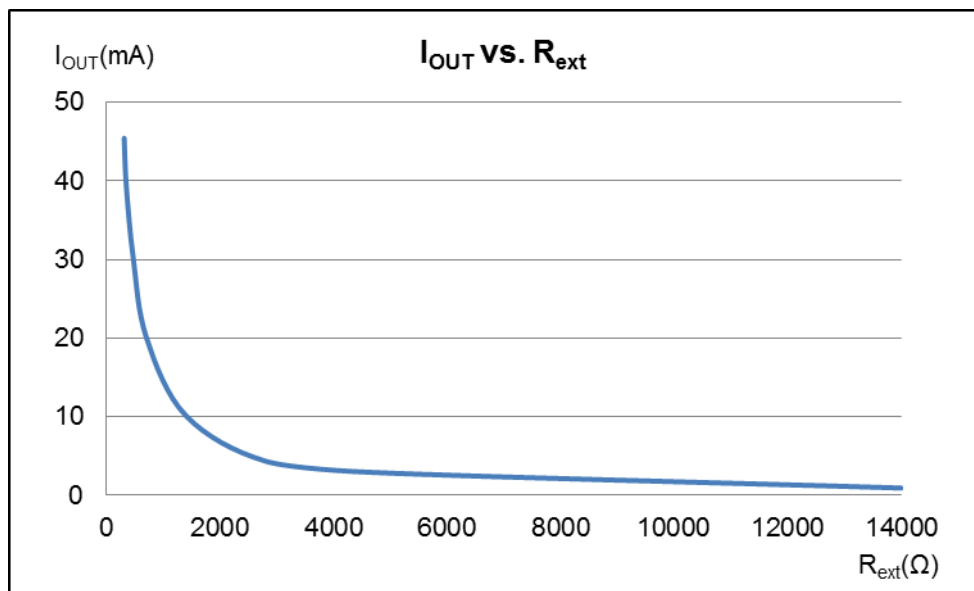

MBI5038 16-Channel Constant Current LED Driver with Error Detection/ Power Saving Mode/ Current Gain Current Gain Adjustment

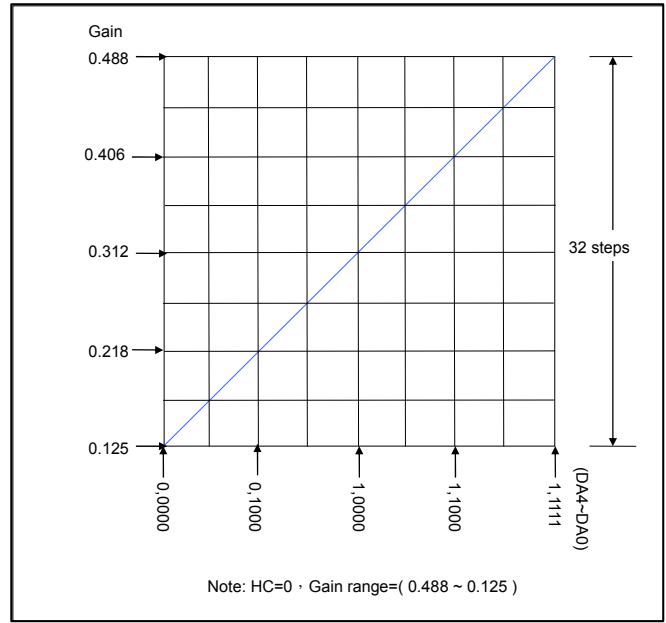
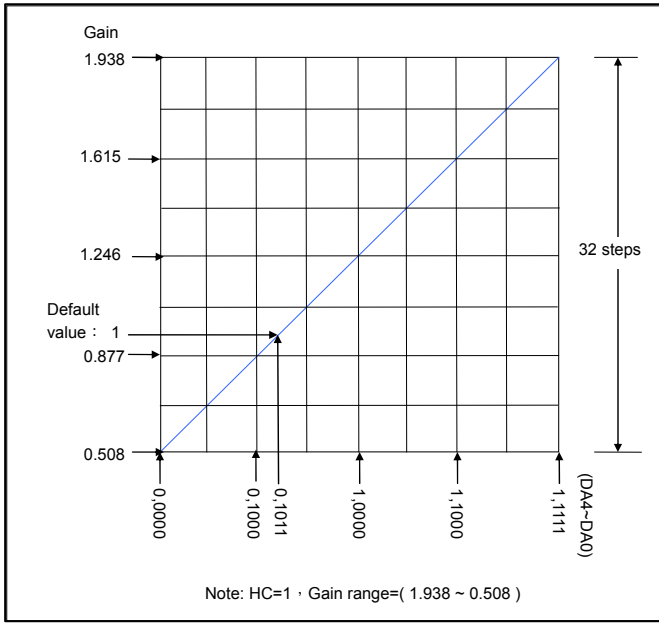

The bit 5 to bit 0 of the configuration register set the gain of output current, i.e., G. As totally 6-bit in number, i.e., ranged from 6'b000000 to 6'b111111, these bits allow the user to set the output current gain up to 64 levels.

These bits can be further defined inside Configuration Register as follows:

F	E	D	C	B	A	9	8	7	6	5	4	3	2	1	0
-	-	-	-	-	-	-	-	-	-	HC	DA4	DA3	DA2	DA1	DA0

1. Bit 5 is HC bit. The setting is in low current band when HC=0, and in high current band when HC=1.
2. Bit 4 to bit 0 are DA4 ~ DA0.

The relationship between these bits and current gain G is:

$$HC=1, D=(65 \times G - 33) / 3$$

$$HC=0, D=(256 \times G - 32) / 3$$

and D in the above decimal numeration can be converted to its equivalent in binary form by the following equation:

$$D = DA4 \times 2^4 + DA3 \times 2^3 + DA2 \times 2^2 + DA1 \times 2^1 + DA0 \times 2^0$$

In other words, these bits can be looked as a floating number with 1-bit exponent HC and 5-bit mantissa DA4~DA0.

For example,

$$HC=1, G=1.246, D=(65 \times 1.246 - 33) / 3 = 16$$

the D in binary form would be:

$$D=16 = 1 \times 2^4 + 0 \times 2^3 + 0 \times 2^2 + 0 \times 2^1 + 0 \times 2^0$$

The 6 bits (bit 5~bit 0) of the configuration register are set to 6'b110000.

Staggered Delay of Output

MBI5038 has a built-in staggered circuit to perform delay mechanism. Among output ports exist a graduated 2ns delay time among $\overline{OUT2n}$, and $\overline{OUT2n+1}$, by which the output ports will be divided to two groups at a different time so that the instant current from the power line will be lowered.

MBI5038 16-Channel Constant Current LED Driver with Error Detection/ Power Saving Mode/ Current Gain Package Power Dissipation (PD)

The maximum allowable package power dissipation is determined as $P_D(max)=(T_j-T_a)/R_{th(j-a)}$. When 16 output channels are turned on simultaneously, the actual package power dissipation is

$P_D(act)=(I_{DD} \times V_{DD})+(I_{OUT} \times Duty \times V_{DS} \times 16)$. Therefore, to keep $P_D(act) \leq P_D(max)$, the allowable maximum output current as a function of duty cycle is:

$$I_{OUT} = \{[(T_j - T_a) / R_{th(j-a)}] - (I_{DD} \times V_{DD})\} / V_{DS} / Duty / 16, \text{ where } T_j = 150^\circ\text{C}.$$

Please see the follow table for P_D and $R_{th(j-a)}$ for different packages:

Device Type	$R_{th(j-a)}$ ($^\circ\text{C}/\text{W}$)	P_D (W)
GF	53	2.36
GP	70	1.79
GM	93.5	1.34

The maximum power dissipation, $P_D(max)=(T_j-T_a)/R_{th(j-a)}$, decreases as the ambient temperature increases.

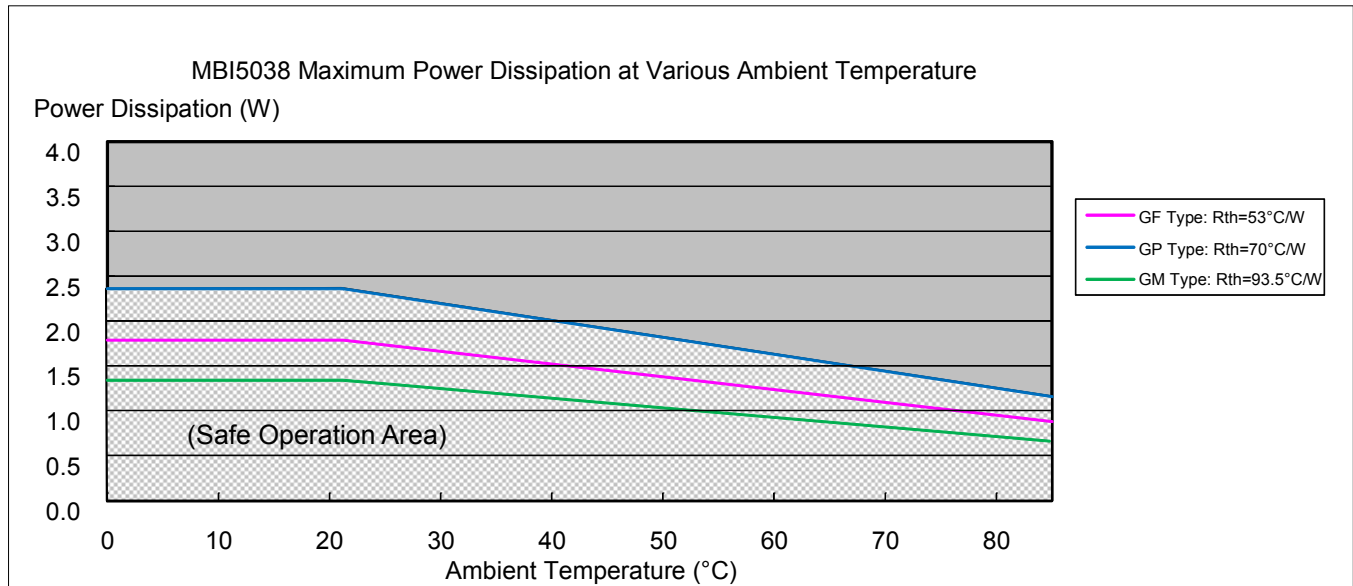

MBI5038 16-Channel Constant Current LED Driver with Error Detection/ Power Saving Mode/ Current Gain Load Supply Voltage (V_{LED})

MBI5038 are designed to operate with V_{DS} ranging from 0.4V to 1.0V considering the package power dissipating limits. V_{DS} may be higher enough to make $P_{D(act)} > P_{D(max)}$ when $V_{LED} = 5V$ and $V_{DS} = V_{LED} - V_f$, in which V_{LED} is the load supply voltage. In this case, it is recommended to use the lowest possible supply voltage or to set an external voltage reducer (V_{DROP}).

A voltage reducer lets $V_{DS} = (V_{LED} - V_f) - V_{DROP}$.

Resistors, or Zener diode can be used in the applications as the following figure.

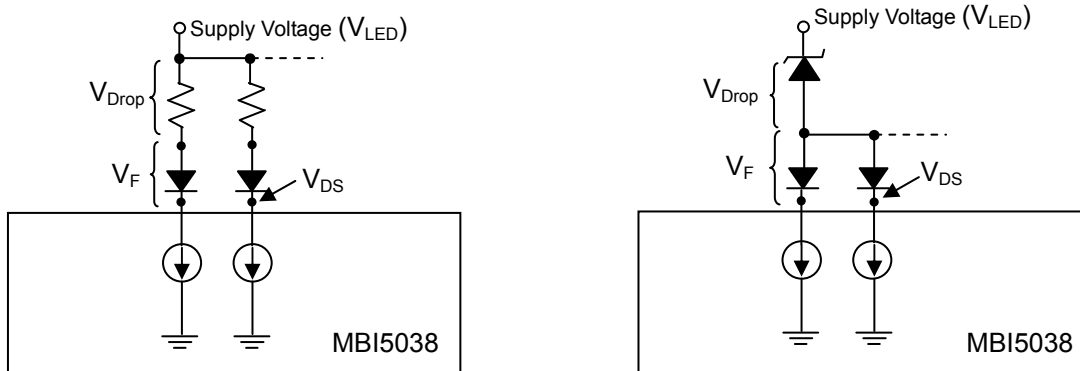

Switching Noise Reduction

LED drivers are frequently used in switch-mode applications which always behave with switching noise due to parasitic inductance on PCB. To eliminate switching noise, refer to "Application Note for 8-bit and 16-bit LED Drivers-Overshoot".

MBI5038 16-Channel Constant Current LED Driver with Error Detection/ Power Saving Mode/ Current Gain Soldering Process of "Pb-free & Green" Package Plating*

Macroblock has defined "Pb-Free & Green" to mean semiconductor products that are compatible with the current RoHS requirements and selected 100% pure tin (Sn) to provide forward and backward compatibility with both the current industry-standard SnPb-based soldering processes and higher-temperature Pb-free processes. Pure tin is widely accepted by customers and suppliers of electronic devices in Europe, Asia and the US as the lead-free surface finish of choice to replace tin-lead. Also, it adopts tin/lead (SnPb) solder paste, and please refer to the JEDEC J-STD-020C for the temperature of solder bath. However, in the whole Pb-free soldering processes and materials, 100% pure tin (Sn) will all require from 245 °C to 260 °C for proper soldering on boards, referring to JEDEC J-STD-020C as shown below.

For managing MSL3 Package, it should refer to JEDEC J-STD-020C about floor life management & refer to JEDEC J-STD-033C about re-bake condition while IC's floor life exceeds MSL3 limitation.

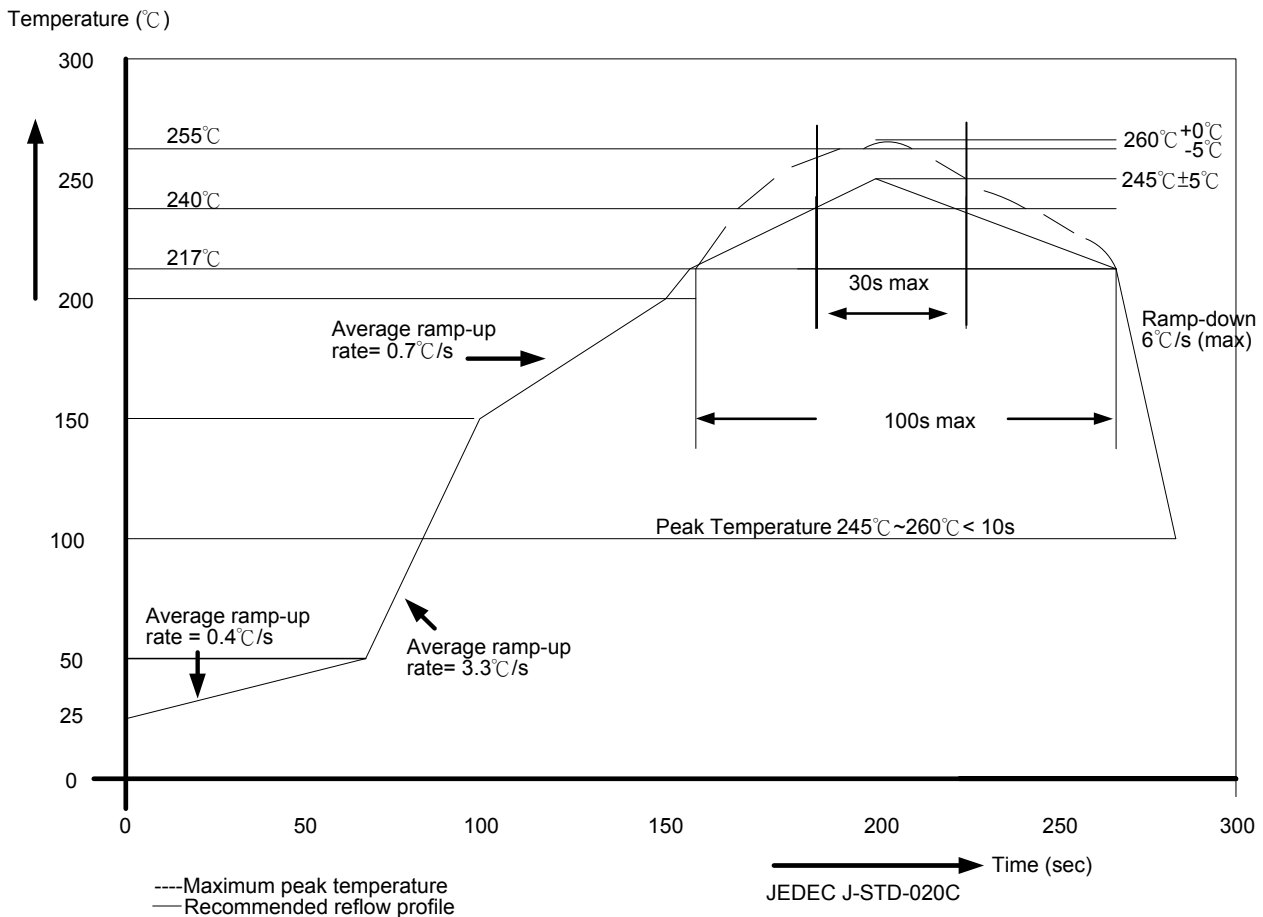

Package Thickness	Volume mm ³ <350	Volume mm ³ 350-2000	Volume mm ³ ≥2000
<1.6mm	260 +0 °C	260 +0 °C	260 +0 °C
1.6mm – 2.5mm	260 +0 °C	250 +0 °C	245 +0 °C
≥2.5mm	250 +0 °C	245 +0 °C	245 +0 °C

*For details, please refer to Macroblock's "Policy on Pb-free & Green Package".

MBI5038 16-Channel Constant Current LED Driver with Error Detection/ Power Saving Mode/ Current Gain Package Outline

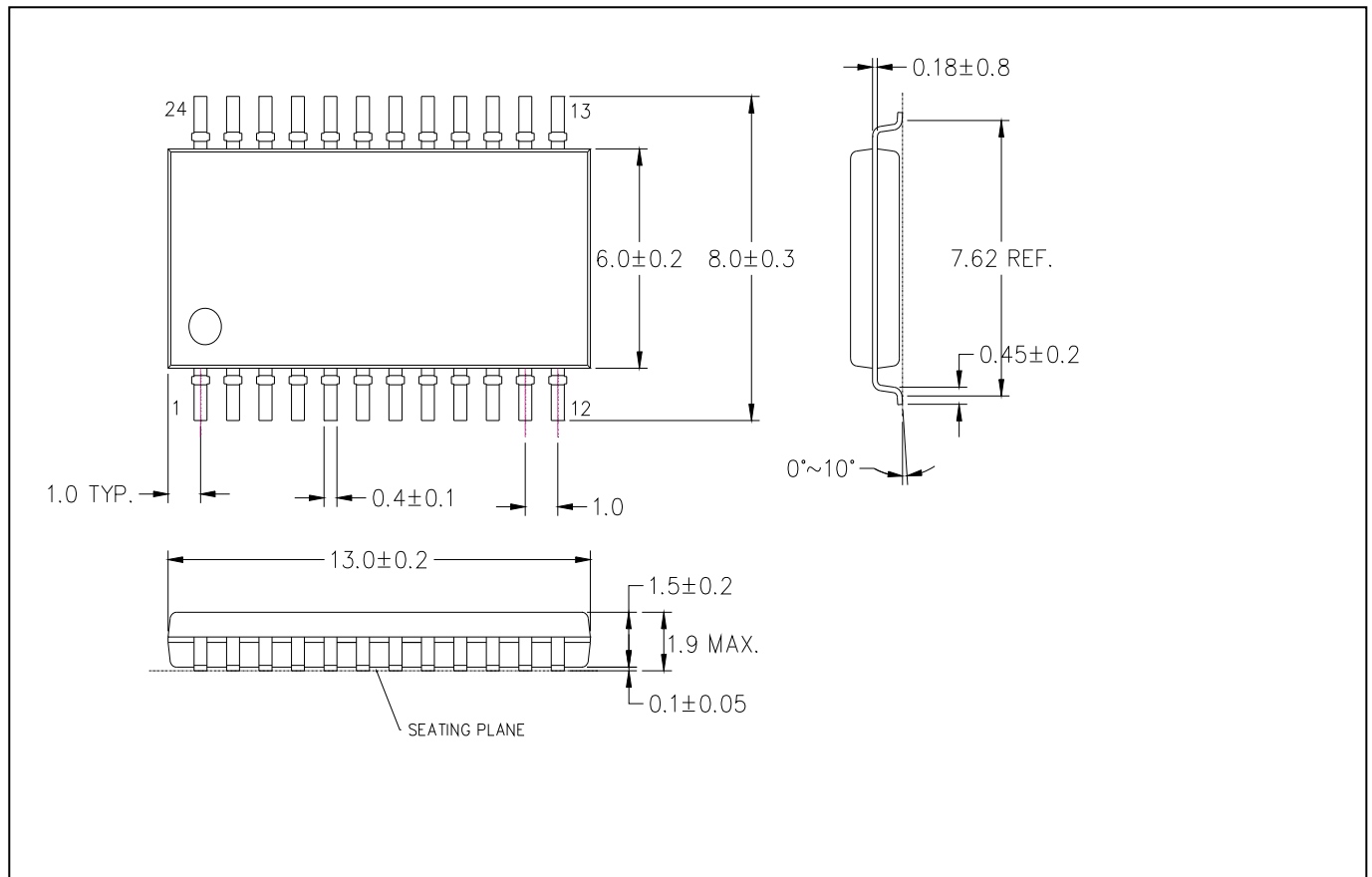

MBI5038 GF Outline Drawing

MBI5038

16-Channel Constant Current LED Driver with Error Detection/ Power Saving Mode/ Current Gain

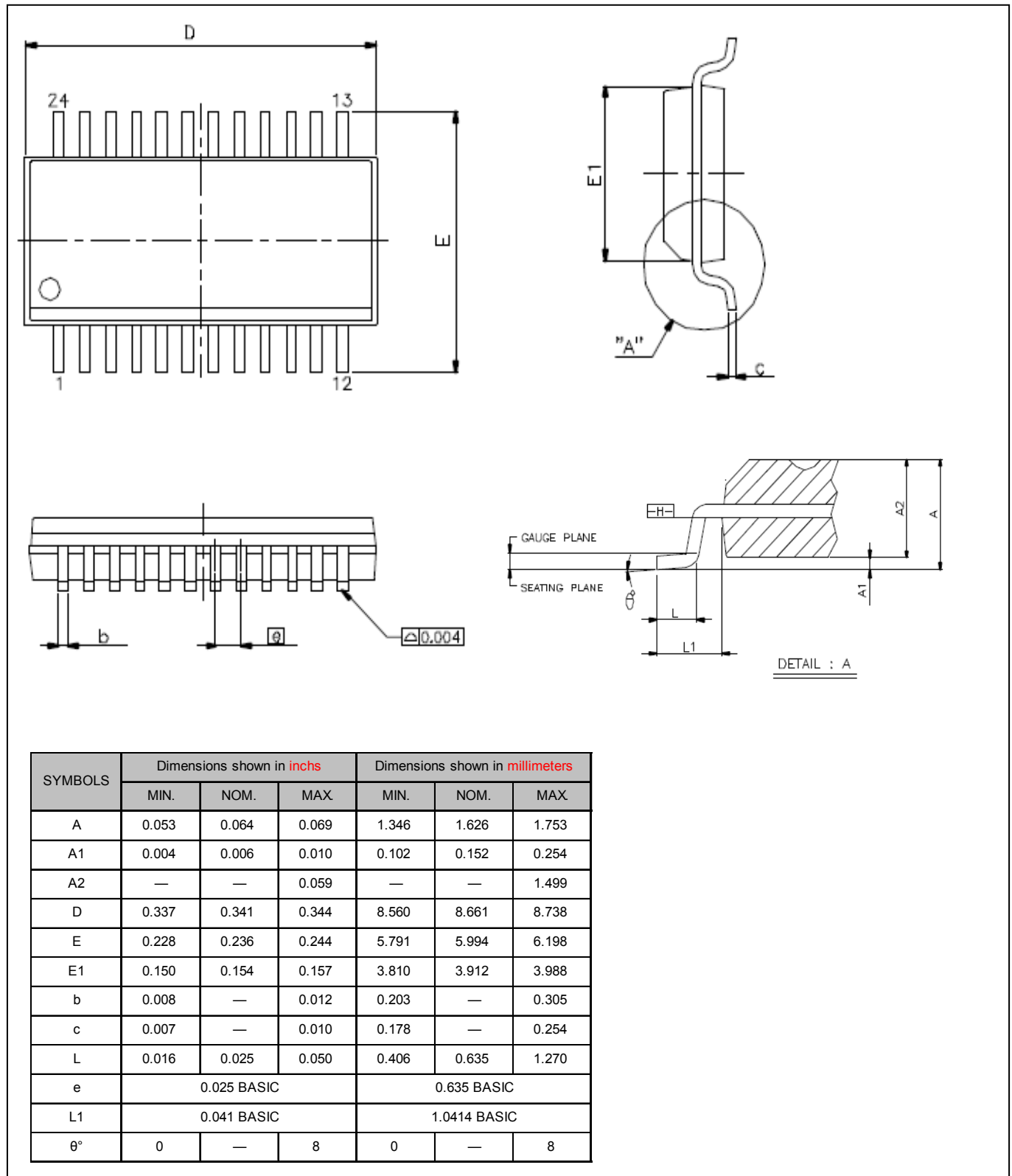

MBI5038 GP Outline Drawing

MBI5038

16-Channel Constant Current LED Driver with Error Detection/ Power Saving Mode/ Current Gain

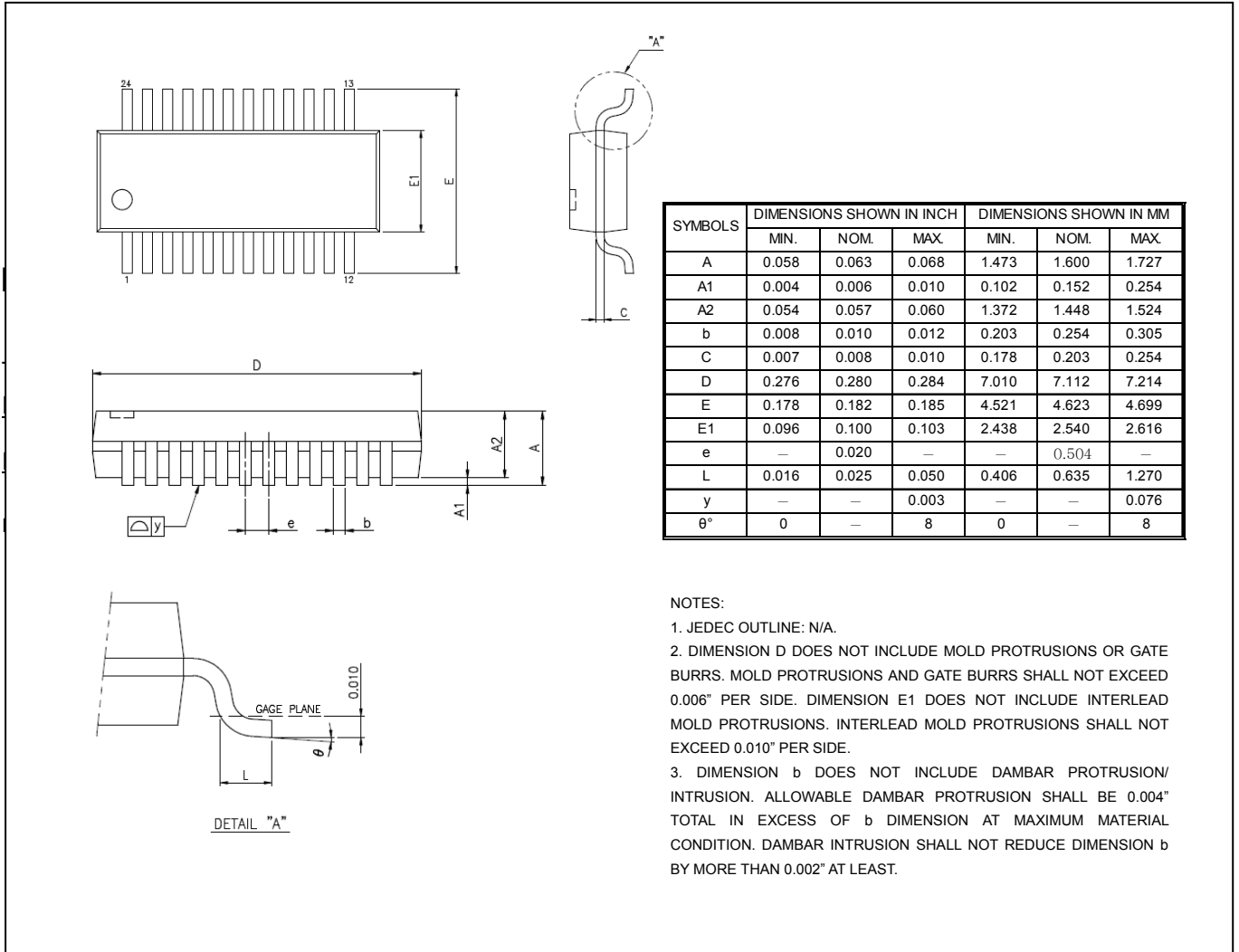

MBI5038 GM Outline Drawing

MBI5038 16-Channel Constant Current LED Driver with Error Detection/ Power Saving Mode/ Current Gain

Product Top-mark Information

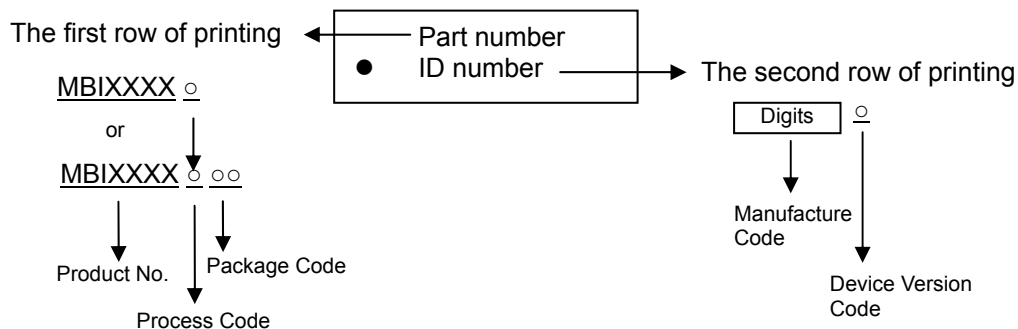

Product Revision History

Datasheet Version	Device Version Code
V1.00	A
V2.00	B
VA.00	B

Product Ordering Information

Part Number	RoHS Compliant Package Type	Weight (g)
MBI5038GF-B	SOP24L-300-1.00	0.28
MBI5038GP-B	SSOP24L-150-0.64	0.11
MBI5038GM-B	mSSOP24L-100-0.5	0.079

*Please place your order with the **“product ordering number”** information on your purchase order (PO).

MBI5038**16-Channel Constant Current LED Driver with
Error Detection/ Power Saving Mode/ Current Gain
Disclaimer**

Macroblock reserves the right to make changes, corrections, modifications, and improvements to their products and documents or discontinue any product or service. Customers are advised to consult their sales representative for the latest product information before ordering. All products are sold subject to the terms and conditions supplied at the time of order acknowledgement, including those pertaining to warranty, patent infringement, and limitation of liability. Macroblock's products are not designed to be used as components in device intended to support or sustain life or in military applications. Use of Macroblock's products in components intended for surgical implant into the body, or other applications in which failure of Macroblock's products could create a situation where personal death or injury may occur, is not authorized without the express written approval of the Managing Director of Macroblock. Macroblock will not be held liable for any damages or claims resulting from the use of its products in medical and military applications.

Related technologies applied to the product are protected by patents. All text, images, logos and information contained on this document is the intellectual property of Macroblock. Unauthorized reproduction, duplication, extraction, use or disclosure of the above mentioned intellectual property will be deemed as infringement.