

General Description

The epc660-BC (Board-to-Board Chip Carrier) is an easy-to-use board with a fully integrated epc660 3D-TOF imager chip with a resolution of 320 x 240 pixels (QVGA). It allows a simple mounting and interconnection to a PCB board which carries the necessary illumination and application system. The lens mounting for standard lenses with lens holders is also easily to be done.

This board is well suited for small and medium volume production of 3D TOF cameras.

Only few additional components are needed to generate a complete 3D camera. Depending on illumination power and optical design, a resolution in the millimeter range for distances up to dozens of meters is feasible. Up to 158 full frame TOF images are delivered in rolling mode. The extremely high sensitivity of the chip allows for a reduced illumination power and reduced overall power consumption compared to other TOF imagers.

An evaluation kit for the epc660 is available with hard- and software examples and a comprehensive manual to speed up system integration.

Features

- epc660 chip assembled on carrier for easy-to-use application
- Easy lens mounting by using standard lens mounts and lenses
- Well suited for small and medium volume production

Applications

- People detection and counting
- Mobile postal parcel size measurement
- Machine safety
- Drone collision avoidance sensing
- Car collision avoidance systems
- Pedestrian detection and breaking systems
- Man-Machine interface
- Gesture control
- Body size measurement
- General volumetric mapping
- Mobile robotics
- Simultaneous localization and mapping (SLAM)

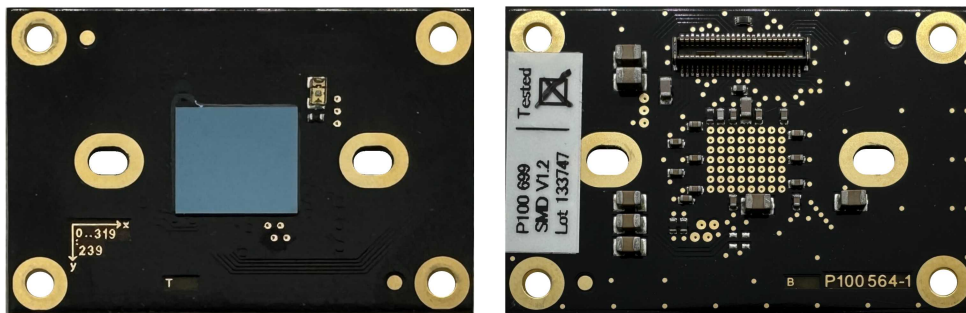

Figure 1: epc660 BC Chip Carrier

1. Ordering information

Part #	Part Name	Description	RoHS
P100 792	epc660-011-BC-003 Chip Carrier	epc660 chip on carrier with board to board connector	yes
P300 761	Lens holder M12 x 0.5	To assemble a lens onto the chip carrier	
P100 506	Lens 149°, 1/2", M12 mount	FOV 108° x 77° on epc660	
P100 843	Lens 88°, 1/2", M12 mount	FOV 70° x 52° on epc660	
P100 596	Lens 38°, 1/2", M12 mount	FOV 31° x 24° on epc660	

Table 1: Ordering Information

2. Operation

This module contains the epc660 chip and all necessary passive components which have to be close to the epc660 chip. The board is designed to be connected to a Hirose DF40GB-48DS connector. All pins necessary to operate the epc660 chip are accessible by this connector. The operation of the epc660 chip is described in detail in the data sheet of epc660.

3. Schematic diagram

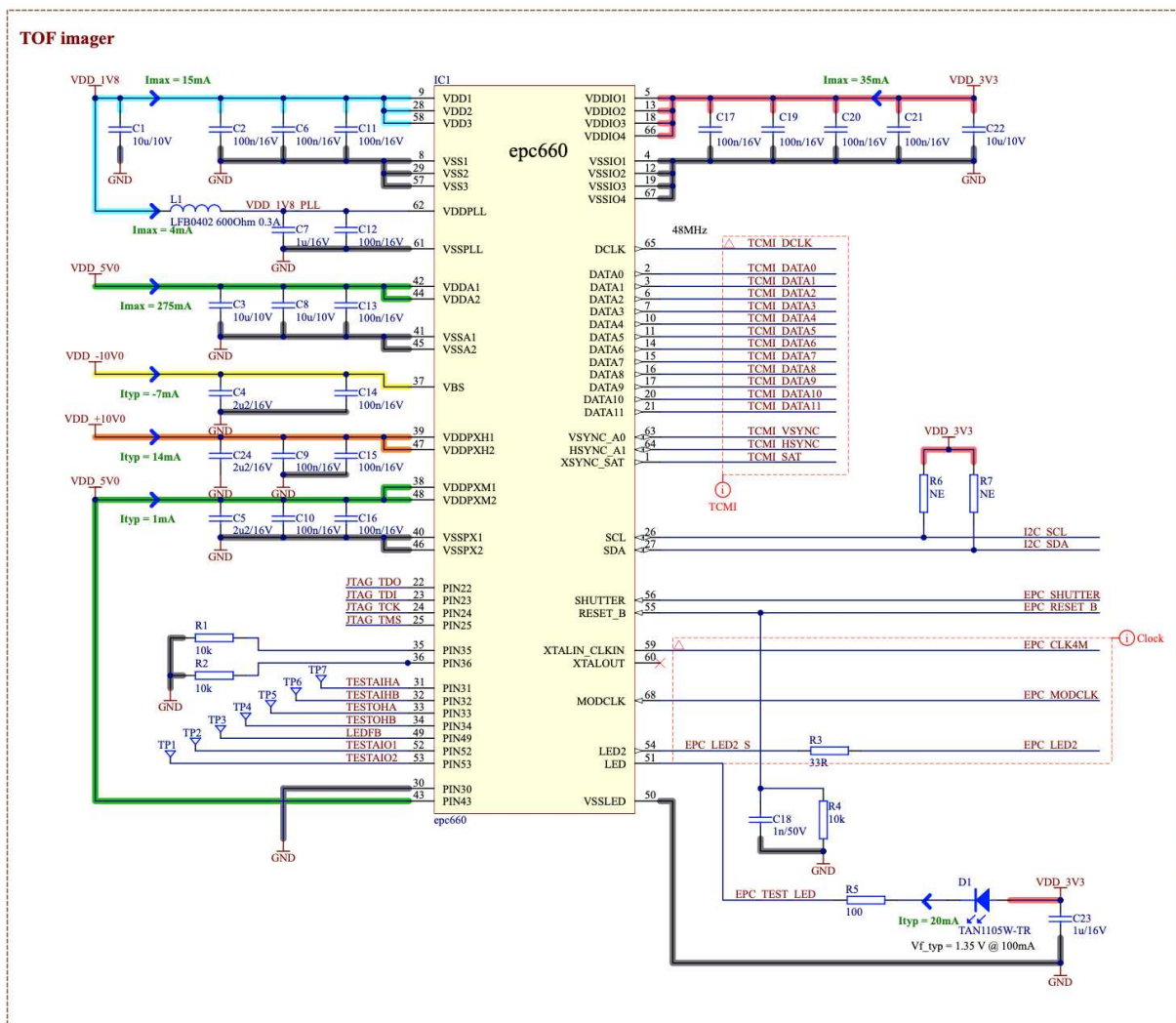

Figure 2: Schematic diagram - TOF imager

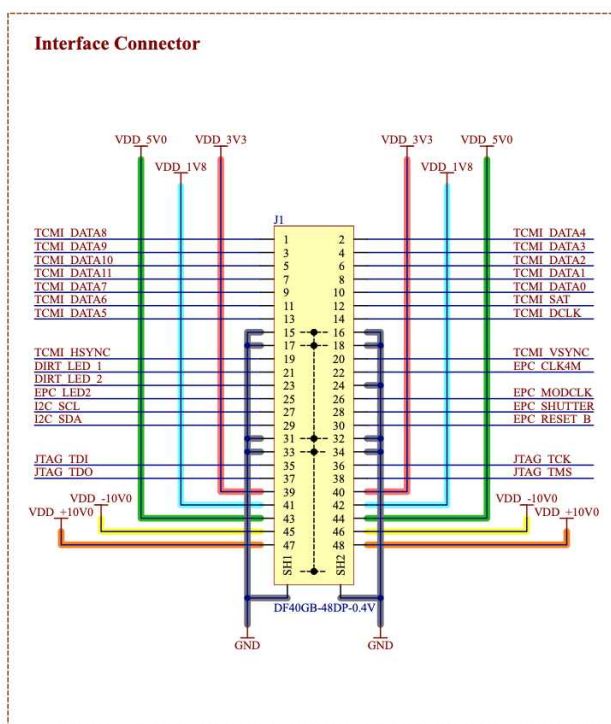

Figure 3: Schematic diagram - Interface Connector

4. Board layout

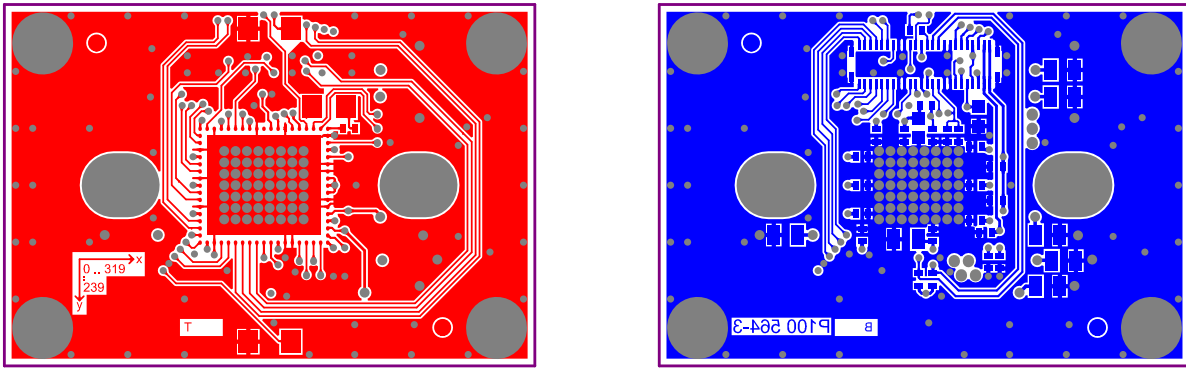

Figure 4: Layout top and bottom

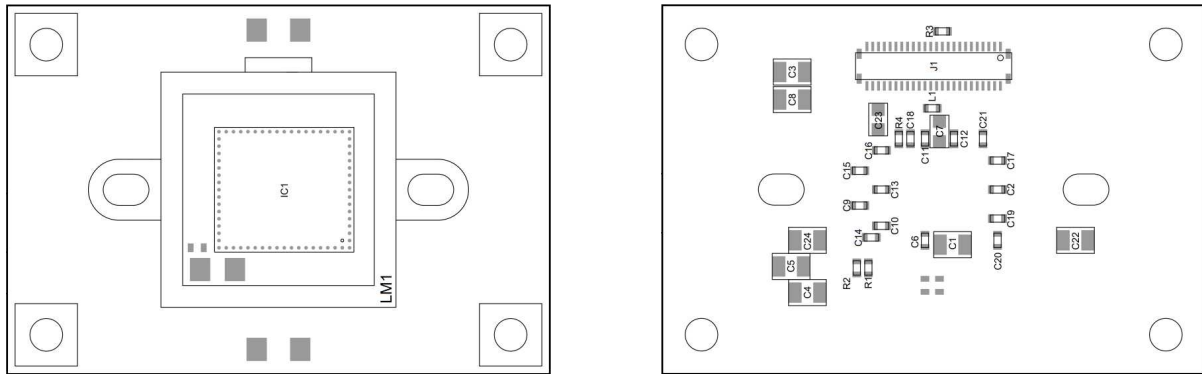

Figure 5: Assembly top and bottom

5. Mechanical dimensions

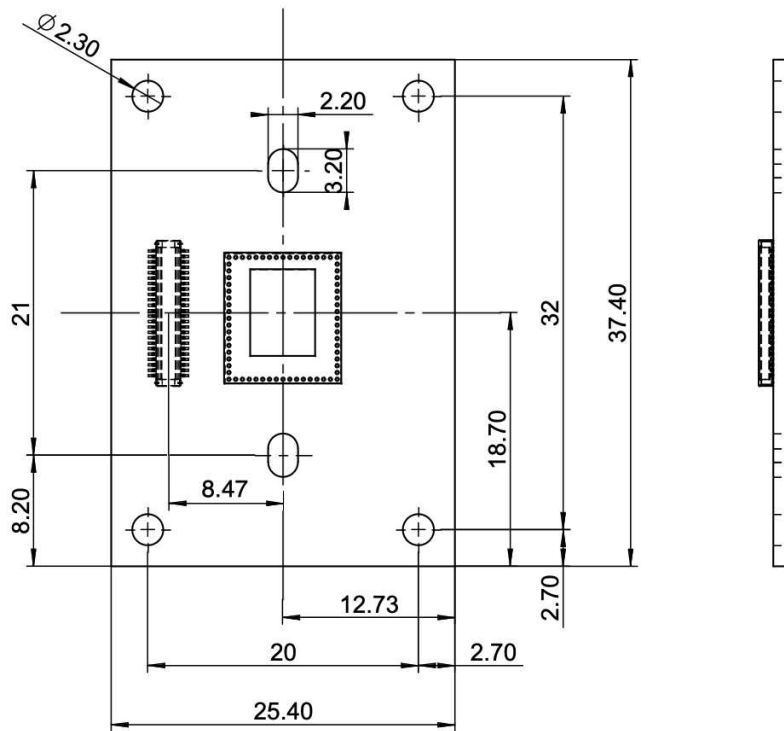

Figure 6: Dimensions
(in mm, bottom view, PCB material is glass epoxy FR-4, thickness 1.6mm)

6. Socket

Figure 7 shows the Hirose Electric J Board-to-Board connectors from the DF40 Series.

The plug DF40GB-48DP-0.4V(58) with outer shroud contacts is assembled on the chip carrier.

A mating receptacle of the DF40 series such as DF40GB(3.0)-48DS-0.4V(51) must be used on the main PCBA.



Figure 7: Vertical Board-to-Board connector

7. Packaging

The parts are delivered in a 56 mm wide carrier tape sealed with an appropriate cover tape.

8. IMPORTANT NOTICE

ESPROS Photonics AG and its subsidiaries (ESPROS) reserve the right to make corrections, modifications, enhancements, improvements, and other changes to its products and services at any time and to discontinue any product or service without notice. Customers should obtain the latest relevant information before placing orders and should verify that such information is current and complete. All products are sold subject to ESPROS' terms and conditions of sale supplied at the time of order acknowledgment.

ESPROS warrants performance of its hardware products to the specifications applicable at the time of sale in accordance with ESPROS' standard warranty. Testing and other quality control techniques are used to the extent ESPROS deems necessary to support this warranty. Except where mandated by government requirements, testing of all parameters of each product is not necessarily performed.

ESPROS assumes no liability for applications assistance or customer product design. Customers are responsible for their products and applications using ESPROS components. To minimize the risks associated with customer products and applications, customers should provide adequate design and operating safeguards.

ESPROS does not warrant or represent that any license, either express or implied, is granted under any ESPROS patent right, copyright, mask work right, or other ESPROS intellectual property right relating to any combination, machine, or process in which ESPROS products or services are used. Information published by ESPROS regarding third-party products or services does not constitute a license from ESPROS to use such products or services or a warranty or endorsement thereof. Use of such information may require a license from a third party under the patents or other intellectual property of the third party, or a license from ESPROS under the patents or other intellectual property of ESPROS.

Resale of ESPROS products or services with statements different from or beyond the parameters stated by ESPROS for that product or service voids all express and any implied warranties for the associated ESPROS product or service. ESPROS is not responsible or liable for any such statements.

ESPROS products are not authorized for use in safety-critical applications (such as life support) where a failure of the ESPROS product would reasonably be expected to cause severe personal injury or death, unless officers of the parties have executed an agreement specifically governing such use. Buyers represent that they have all necessary expertise in the safety and regulatory ramifications of their applications, and acknowledge and agree that they are solely responsible for all legal, regulatory and safety-related requirements concerning their products and any use of ESPROS products in such safety-critical applications, notwithstanding any applications-related information or support that may be provided by ESPROS. Further, Buyers must fully indemnify ESPROS and its representatives against any damages arising out of the use of ESPROS products in such safety-critical applications.

ESPROS products are neither designed nor intended for use in military/aerospace applications or environments unless the ESPROS products are specifically designated by ESPROS as military-grade. Only products designated by ESPROS as military-grade meet military specifications. Buyers acknowledge and agree that any such use of ESPROS products which ESPROS has not designated as military-grade is solely at the Buyer's risk, and that they are solely responsible for compliance with all legal and regulatory requirements in connection with such use.

ESPROS products are neither designed nor intended for use in automotive applications or environments unless the specific ESPROS products are designated by ESPROS as compliant with ISO/TS 16949 requirements. Buyers acknowledge and agree that, if they use any non-designated products in automotive applications, ESPROS will not be responsible for any failure to meet such requirements.